

YATES INDUSTRIES YS-MIL MILL CYLINDERS

PLEASE CHECK THE APPROPRIATE DESIGNATIONS OR FILL IN INFORMATION WHERE REQUIRED.

Air service _____ Low pressure Hyd _____ High pressure hydraulic _____
If hydraulic indicate working pressure _____ Max rated pressure _____
Bore Diameter: _____ Stroke Length _____ Rod Diameter _____
Mounting style: _____
Rod end style: Male _____ Female _____ Other _____
Specify thread dia., pitch and length (i.e. 1 1/4-14 male x 1 5/8" long.) _____
Cushion on rod end _____ Cushion on cap end _____ Location of adjustments _____
Type of Port: NPTF _____ SAE _____ 4 bolt flange _____ Other (specify) _____
Port size rod end _____ Port size cap end _____ Location of ports _____
Operating fluid used _____ Operating temp _____
Special features required: _____

**SUPPLY ALL PERTINENT INFORMATION FROM EXISTING CYLINDER TAGS OR DESCRIPTIONS
AS WELL AS ANY DRAWINGS, SKETCHES OR PHOTOS AVAILABLE.**

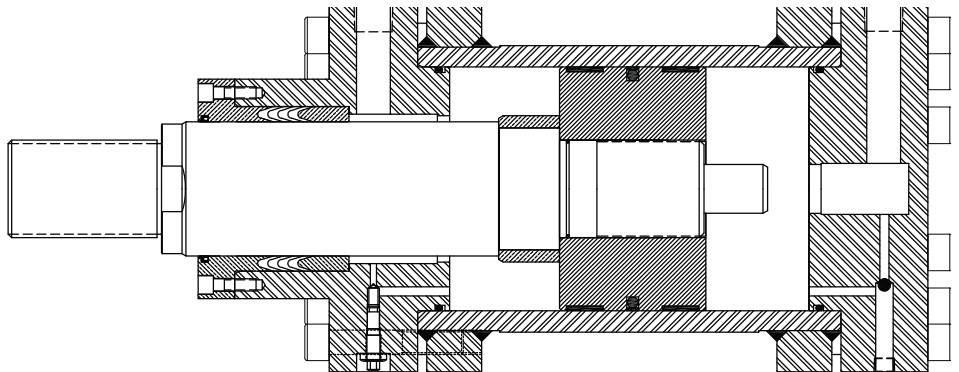
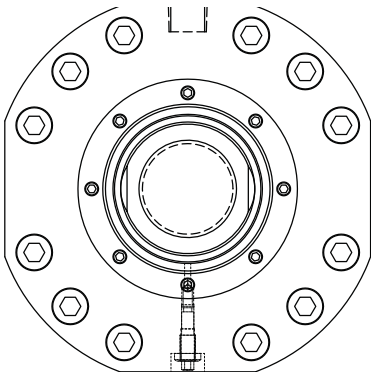

YATES INDUSTRIES YS-MIL MILL CYLINDERS

YS-MIL-A AIR SERVICE/ 200 PSI HYDRAULIC MILL CYLINDERS SPECIFICATIONS:

- 1. CYLINDER BODY**- honed to a micro finish with ends chamfered for assembly purposes. All flanges and mounting trunnions are rigidly welded to the cylinder tube. Chrome plating is available as an option.
- 2. HEAD AND CAP**- rugged construction, heads provide long male pilots for proper alignment with body.
- 3. PISTON**- one piece cast iron construction threaded on rod and positively locked. Optional bronze overlay pistons available on request.
- 4. PISTON ROD** - 100,000 psi tensile steel, turned, ground and polished with .001" hard chrome plating is standard. Heavy chrome is available as an option.
- 5. CUSHIONS** - floating rod end cushion, integral cap end spear. Needle valve and ball check provide a wide range of cushion adjustment while allowing quick break away.
- 6. IN-BOARD AND OUT-BOARD ROD BUSHINGS** - precision machined from bronze for long life. Allows easy removal of rod packing without disassembly.
- 7. PISTON SEALS** - standard u-cup design is suitable for most applications. Optional teflon glide ring and double wear bands are optional.
- 8. ROD SEALS** - v-ring packing provides leak proof operation at all pressures. Polyurethane rod wiper is standard; metallic rod scraper is available.
- 9. HEAD & CAP BOLTS** - thru bolt construction with high strength socket head screws and nuts.

YS-MIL-H HEAVY DUTY HYDRAULIC MILL CYLINDERS TO 3000 PSI SPECIFICATIONS:

- 1. CYLINDER BODY** - honed to a micro finish with ends chamfered for assembly purposes. All flanges and mounting trunnions are rigidly welded to the cylinder tube. Chrome plating is available as an option.
- 2. HEAD AND CAP** - rugged construction, heads provide long male pilots for proper alignment with body.
- 3. PISTON** - one piece cast iron construction threaded on rod and positively locked. Optional bronze overlay pistons available on request.
- 4. PISTON ROD** - 100,000 psi tensile steel, turned, ground and polished with .001" hard chrome plating is standard. Heavy chrome is available as an option.
- 5. CUSHIONS** - Bronze rod end cushion sleeve, integral cap end spear. Needle valve and ball check provide a wide range of cushion adjustment while allowing quick break away.
- 6. IN-BOARD AND OUT-BOARD ROD BUSHINGS** - precision machined from bronze for long life. Allows easy removal of rod packing without disassembly.
- 7. PISTON SEALS** - polypak piston seal design is suitable for most applications. Optional teflon glide ring and double wear bands or cast iron rings are optional.
- 8. ROD SEALS** - v-ring packing provides leak proof operation at all pressures or polypak seals available in optional materials based on application. Polyurethane rod wiper is standard; metallic rod scraper is available.
- 9. HEAD & CAP BOLTS** - thru bolt construction with high strength socket head screws and nuts.

MILL CYLINDER HOW TO ORDER INFORMATION

Unlike the N.F.P.A. tie rod cylinders that are made to certain specifications that ensures all manufacturers' mounting will be interchangeable, mill cylinders have no such standard. Each manufacturer has their own dimensions and designs so care must be taken when replacing an existing cylinder. Please fill out the information on page 127 and our factory will provide a blank dimensional drawing for the particular mount that will need to be filled in with appropriate dimensions to allow us to match the original cylinder.