

HEAVY DUTY PNEUMATIC
Series A4

MEDIUM DUTY HYDRAULIC
Series H4

PERMANENTLY LUBRICATED HEAVY DUTY PNEUMATIC
Series L4



A4/L4/H4 FEATURES

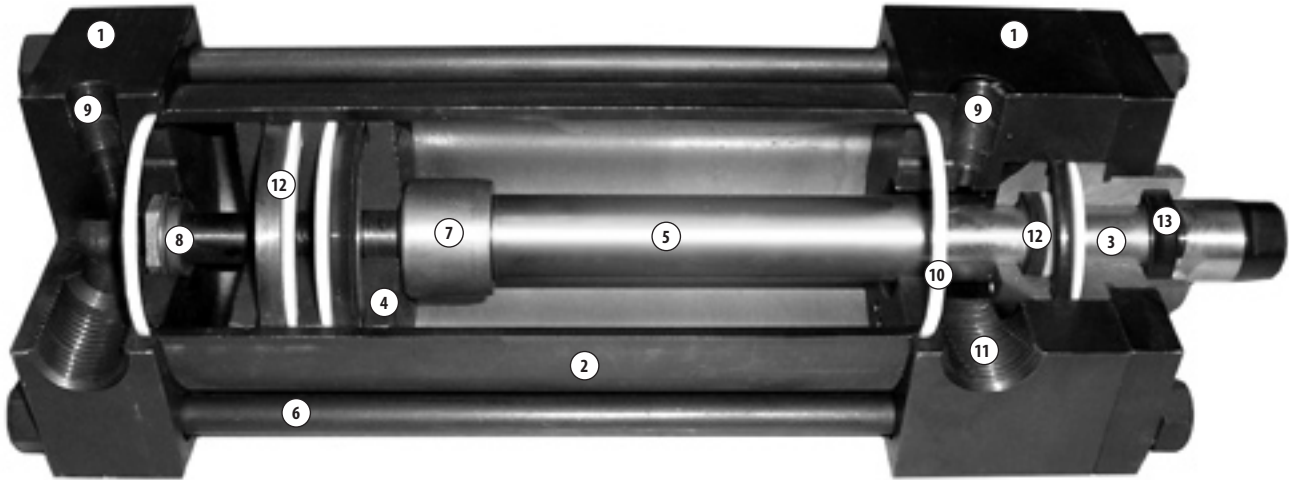

- 1. HEAD/CAP-** Precision machined steel head and cap provide close concentricity and accurate alignment between piston, tube, piston rod and rod bearing.
- 2. CYLINDER BARREL-** Damage resistant tubing honed to an 8 to 16 micro finish for low frictional drag and maximum seal life. Hard chrome plated to resist corrosion and scoring.
- 3. ROD CARTRIDGE-** Extra long, high strength bronze gland provides maximum bearing support and wear resistance. With certain exceptions, a removable retainer allows for gland removal without cylinder disassembly.
- 4. PISTON-** One piece fine grained cast iron piston provides maximum strength and protection against shock loads. Anaerobic adhesive is used to permanently lock and seal the piston to the rod.
- 5. PISTON ROD-** High strength, damage resistant piston rod provides 100,000 PSI minimum yield material in 5/8" through 4 1/2" diameters. Larger diameters vary between 50,000 and 75,000 PSI minimum yield material. All rods are case hardened to 50-55 RC and hard chrome plated to provide maximum wear life. Stainless steel is also available.
- 6. TIE RODS-** 100,000 to 125,000 PSI minimum yield steel, pre-stressed for fatigue resistance, and roll threaded for added strength.
- 7. HEAD CUSHIONS-** Self centering head cushion design provides consistent cushioning performance.
- 8. CAP CUSHIONS-** Floating cap cushion insert design replaces ball check to provide greater flow area for fast break-away and provides consistent cushioning performance.
- 9. CUSHION NEEDLE ADJUSTMENT AND BALL CHECK-** Flush mounted captive cushion adjustment allows safe cushion adjustment under pressure. Special tip design and fine threads allow precise adjustment over a broad range of operations. Cushion ball check provided at head end allows for fast break-away under full power.
- 10. TUBE SEALS-** Extrusion resistant Teflon® material is compatible with virtually all fluids and can operate in temperatures to 500°F.
- 11. PORTS-** NPT ports are standard and can be rotated to any 90 degree position in relation to each other and the mounting. SAE ports optional.
- 12. RODS AND PISTON SEALS-** Pressure energized nitrile U-cups, with Teflon® back-up rings are standard. Step cut cast iron rings and Viton® seals for temperatures to 400°F are optional. Special seals for low friction, high speed applications are also available.
- 13. ROD WIPER-** Nitrile double lip rod wiper acts as secondary seal while keeping dirt, dust and other contaminants out. Optional Viton® wiper available for fluid compatibility or temperatures to 400°F. Metallic scrapers and low friction wipers also available.

SIDE MOUNTS

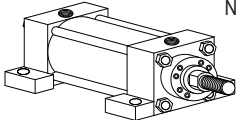
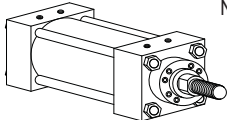
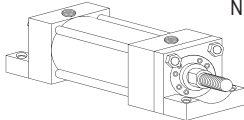
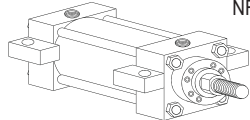
<p>STYLE A PAGE 44-47 NFPA-MS2</p>  <p>SIDE LUGS 1 1/2-20" BORE</p>	<p>STYLE B PAGE 44-47 NFPA-MS4</p>  <p>SIDE TAPPED 1 1/2-20" BORE</p>	<p>STYLE E PAGE 48-49 NFPA-MS7</p>  <p>SIDE END LUGS 1 1/2-14" BORE</p>	<p>STYLE H PAGE 44-47 NFPA-MS3</p>  <p>CENTER-LINE LUGS 1 1/2-20" BORE</p>
--	--	---	---

END MOUNTS

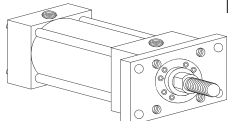
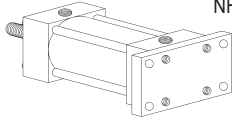
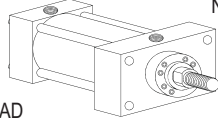
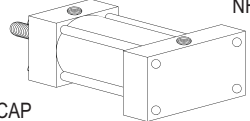
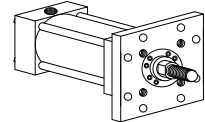
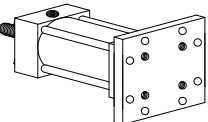
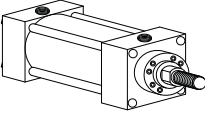
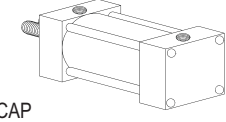
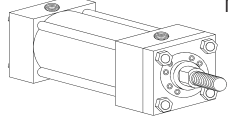
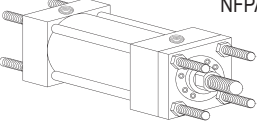
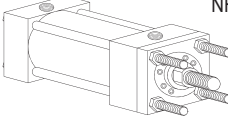
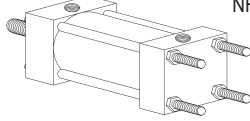
<p>STYLE F PAGE 62-63 NFPA-MF1</p>  <p>HEAD RECTANGULAR FLANGE 1 1/2-6" BORE</p>	<p>STYLE R PAGE 62-63 NFPA-MF2</p>  <p>CAP RECTANGULAR FLANGE 1 1/2-6" BORE</p>	<p>STYLE G PAGE 64-65 NFPA-ME5</p>  <p>HEAD RECTANGULAR INTEGRAL FLANGE 1 1/2-6" BORE</p>	<p>STYLE P PAGE 64-65 NFPA-ME6</p>  <p>CAP RECTANGULAR INTEGRAL FLANGE 1 1/2-6" BORE</p>
<p>STYLE J PAGE 62-63 NFPA-MF5</p>  <p>HEAD SQUARE FLANGE 1 1/2-6" BORE</p>	<p>STYLE S PAGE 62-63 NFPA-MF6</p>  <p>CAP SQUARE FLANGE 1 1/2-6" BORE</p>	<p>K PAGE 66-67 NFPA-ME3</p> 	<p>STYLE Z PAGE 66-67</p>  <p>CAP SQUARE INTEGRAL FLANGE 8-20" BORE</p>
<p>STYLE K PAGE 68-71 NFPA-MX0</p>  <p>NO TIE RODS EXTENDED 1 1/2-20" BORE</p>	<p>STYLE L PAGE 68-71 NFPA-MX1</p>  <p>BOTH ENDS TIE RODS EXTENDED 1 1/2-20" BORE</p>	<p>STYLE M PAGE 68-71 NFPA-MX3</p>  <p>HEAD TIE RODS EXTENDED 1 1/2-20" BORE</p>	<p>STYLE N PAGE 68-71 NFPA-MX2</p>  <p>CAP TIE RODS EXTENDED 1 1/2-20" BORE</p>

PIVOT MOUNTS – CLEVIS AND EYE

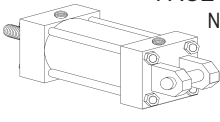
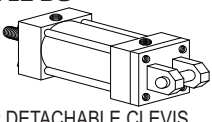
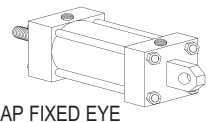
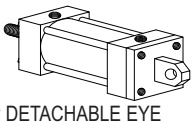
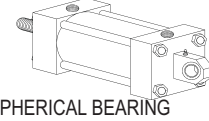
<p>C PAGE 52-55 NFPA-MP1</p> 	<p>STYLE DC PAGE 56-57</p>  <p>CAP DETACHABLE CLEVIS 1 1/2-6" BORE</p>
<p>STYLE V PAGE 52-55 NFPA-MP3</p>  <p>CAP FIXED EYE 1 1/2-20" BORE</p>	<p>STYLE DV PAGE 56-57 NFPA-MP4</p>  <p>CAP DETACHABLE EYE 1 1/2-6" BORE</p>
<p>STYLE Q PAGE 50-51 NFPA-MPU3</p>  <p>SPHERICAL BEARING 1 1/2-14" BORE</p>	

PIVOT MOUNTS – TRUNNION

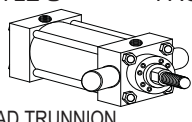
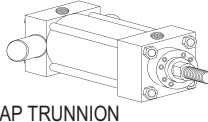
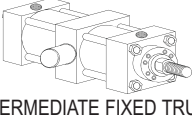
<p>STYLE U PAGE 58-61 NFPA-MT1</p>  <p>HEAD TRUNNION 1 1/2-20" BORE</p>
<p>STYLE W PAGE 58-61 NFPA-MT2</p>  <p>CAP TRUNNION 1 1/2-20" BORE</p>
<p>STYLE T PAGE 58-61 NFPA-MT4</p>  <p>INTERMEDIATE FIXED TRUNNION 1 1/2-14" BORE</p>

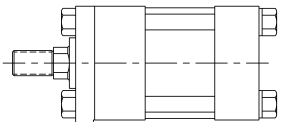
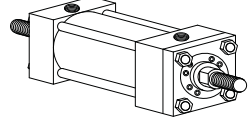
<p>EXTENDED KEY PLATE (ADD "S" IN PART # AND STATE EXTENDED KEY PLATE IN DESCRIPTION)</p>  <p>1 1/2-6" BORE PAGE 73</p>
<p>DOUBLE ROD END (ADD "D" AFTER STYLE)</p>  <p>1 1/2-20" BORE PAGE 72-73</p>



PRESSURE RATINGS

AIR SERVICE: USE PRESSURES UP TO 250 PSI

CYLINDER BORE (INCHES)	PISTON ROD DIAMETER (INCHES)			PRESSURE RATINGS (PSI)	
	STANDARD	OVERSIZE	2:1	HEAVY-DUTY SERVICE	4:1 SAFETY FACTOR
1 1/2	5/8		1	1500 *	1800
2	5/8	1	1 3/8	1400 *	950
2 1/2	5/8	1, 1 3/8	1 3/4	1100 *	600
3 1/4	1	1 3/8, 1 3/4	2	1300 *	900
4	1	1 3/8, 1 3/4, 2	2 1/2	900 *	650
5	1	1 3/8, 1 3/4, 2, 2 1/2, 3	3 1/2	750 *	650
6	1 3/8	1 3/4, 2, 2 1/2, 3, 3 1/2	4	700 *	450
8	1 3/8	1 3/4, 2, 2 1/2, 3, 3 1/2, 4, 4 1/2, 5		500 *	550
10	1 3/4	2, 2 1/2, 3, 3 1/2, 4, 4 1/2, 5, 5 1/2		400 *	350
12	2	2 1/2, 3, 3 1/2, 4, 4 1/2, 5, 5 1/2		400 *	
14	2 1/2	3, 3 1/2, 4, 4 1/2, 5, 5 1/2		400 *	
16	3 1/2	4, 4 1/2, 5, 5 1/2		450 *	
18	4	4 1/2, 5, 5 1/2		400 *	
20	4	4 1/2, 5, 5 1/2		400 *	

FOR HIGHER PRESSURES CONSULT FACTORY

* PRESSURE FOR "F" AND "R" MOUNTS (SEE PAGE 63) AND "Q" MOUNT (SEE PAGES 50 & 51) IS LOWER

Ø 4:1 SAFETY FACTOR BASED ON FAILURE PRESSURES OF WEAKEST COMPONENT AND STANDARD ROD SIZE

RETAINER INFORMATION

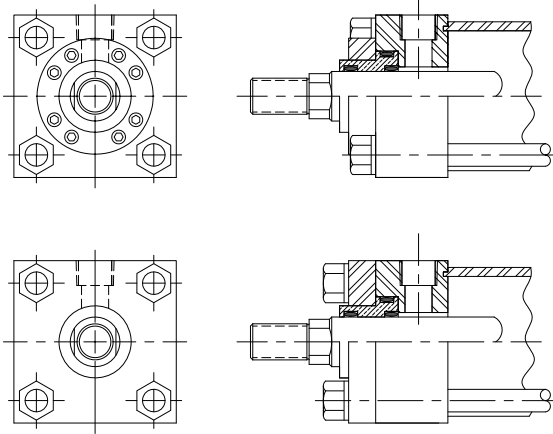

**A4 and H4 cylinders with the following bore and rod combinations:
Use circular retainers which permit removal of rod cartridge without disassembling cylinder.**

- 2 1/2" bore with 5/8" and 1" rods
- 3 1/4" bore with 1" and 1 3/8" rods
- 4" bore with 1", 1 3/8", 1 3/4", and 2" rods
- 5" bore with 1", 1 3/8", 1 3/4", 2", and 2 1/2" rods
- 6" bore with 1 3/8", 1 3/4", 2", 2 1/2", 3", and 3 1/2" rods
- 8" thru 20" bores with all rod diameters

**A4 and H4 cylinders with the following bore and rod combinations:
Use full plate retainer construction.**

- 1 1/2" bore with 5/8 and 1" rods
- 2" bore with 5/8", 1", and 1 3/8" rods
- 2 1/2" bore with 1 3/8" and 1 3/4" rods
- 3 1/4" bore with 1 3/4" and 2" rods
- 4" bore with 2 1/2" rod
- 5" bore with 3" and 3 1/2" rods
- 6" bore with 4" rod

TIE ROD INFORMATION

On large bore cylinders, two tie rods are used at each corner of the 16, 18 and 20 inch bore sizes. This reduces flexing of head and cap under pressure.

BORE	RA	RB	TIE ROD THREAD
16	7.745	5.234	1-14
18	8.396	5.879	1 1/8-12
20	9.266	6.488	1 1/4-12

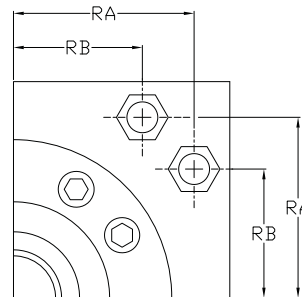

HOW TO ORDER A4/H4/L4 CYLINDERS

FEATURE	DESCRIPTION	PAGE #	SYMBOL	A	4	-	A	D	N	3	.	2	N	4	5	.	6	3	N	1	.	3	8	N	2	S	1	1		
Series	Steel air service Medium duty Hydraulic Permanently lubricated air	42	A4 H4 L4	←																										
Mounting Style	Side lugs (MS2) Side tapped (MS4) Side end lugs (MS7) Center-line lugs (MS3) Head rectangular flange (MF1) Cap rectangular flange (MF2) Head square flange (MF5) Cap square flange (MF6) Head rectangular integral flange (ME5) Cap rectangular integral flange (ME6) Head square integral flange (ME3) Cap square integral flange (ME4) No tie rods extended (MX0) Both ends tie rods extended (MX1) Head tie rods extended (MX3) Cap tie rods extended (MX2) Cap clevis (MP1) Cap detachable clevis (MP2) Cap eye (MP3) Cap detachable eye (MP4) Spherical bearing (MPU3) Head trunnion (MT1) Cap trunnion (MT2) Intermediate fixed trunnion (MT4)	41	A B E H F R J S G P X Z K L M N C DC V DV Q U W T	←																										
Double Rod Cushions	Double rod design if needed No cushions Cushion head end only Cushion cap end only Cushioned both ends	72	D N R C B	←																										
Bore Size	Specify in inches	106-107		←																										
Piston Seals	Nitrile U-cups Cast iron rings Poly seals Viton® seals Fluorocarbon poly seals Other (Specify)	120	N C P V F X	←																										
Stroke	Specify in inches with 2 place decimal	107		←																										
Ports	NPTF SAE Welded coupler Other (Specify)		N S W X	←																										
Rod DIA.	Specify in inches	106-107		←																										
Rod Seals	Twin lip hydraulic seal (H4) Std Nitrile U-cups (A4/L4) Std Poly seals Viton® seals Fluorocarbon poly seals Other (Specify)	120	T N P V F X	←																										
Rod End	Standard male Standard female Intermediate male Long female Extended standard male Extended intermediate male Plain rod end Male full thread Male rod coupling Special male (specify) Special female (specify) Special stud (specify) Special other (specify)	77	2 4 1 3 5 6 7 8 9 M F S X	←																										
Specials Specify	High load piston Stop tube Proximity switches Non-standard mount Stainless steel rod Extra rod extension Many more options available	120	S	←																										
Head port	specify location 1-4		1-4	←																										
Cap port	specify location 1-5		1-5	←																										



SIDE LUGS MOUNT

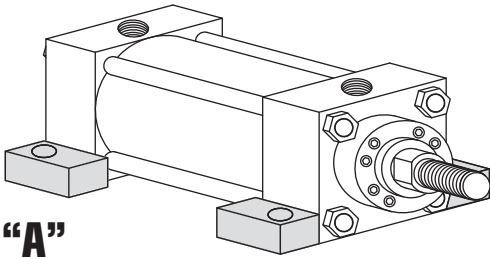

"A"
YATES STYLE A
NFPA-MS2

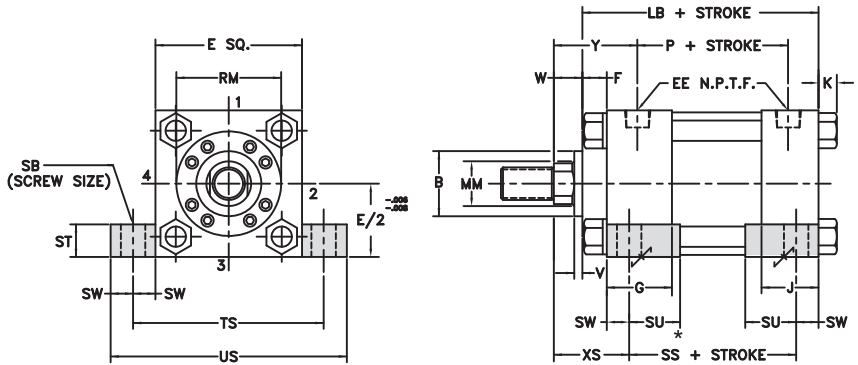

SIDE TAPPED MOUNT

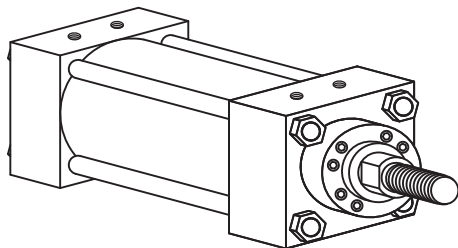

"B"
YATES STYLE B
NFPA-MS4

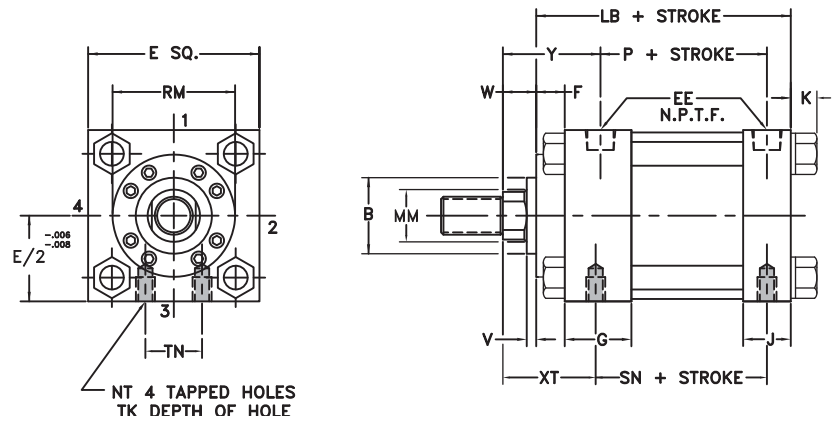

CENTER-LINE LUGS MOUNT

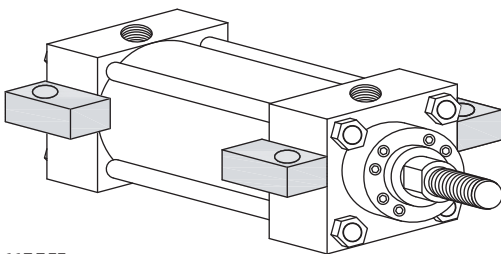

"H"
YATES STYLE H
NFPA-MS3

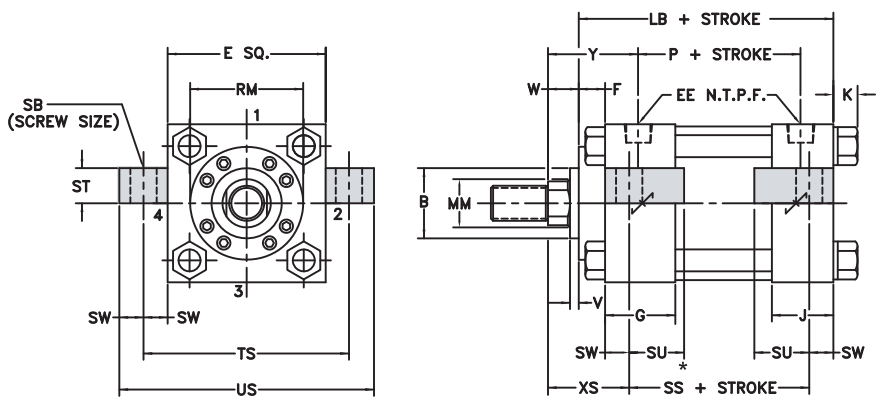

STANDARD ROD ENDS

#2 STD MALE
NFPA-SM

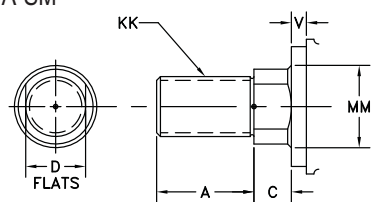

#4 STD FEMALE
NFPA-SF

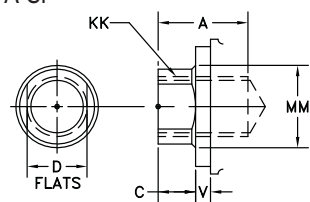

#1 MALE
NFPA-IM

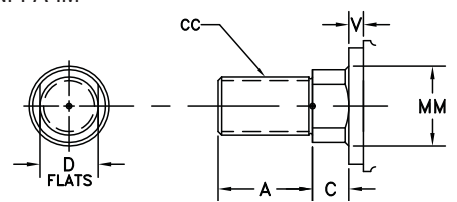

BORE	SAE															ADD STROKE			
	E	EE	OPT	F	G	J	K	SB	ST	SU	SW	TS	US	NT	TN	LB	P	SS *	SN
1 1/2	2	3/8	6	3/8	1 1/2	1	1/4	3/8	1/2	15/16	3/8	2 3/4	3 1/2	1/4-20	5/8	4	2 3/16	2 7/8	2 1/4
2	2 1/2	3/8	6	3/8	1 1/2	1	5/16	3/8	1/2	15/16	3/8	3 1/4	4	5/16-18	7/8	4	2 3/16	2 7/8	2 1/4
2 1/2	3	3/8	6	3/8	1 1/2	1	5/16	3/8	1/2	15/16	3/8	3 3/4	4 1/2	3/8-16	1 1/4	4 1/8	2 5/16	3	2 3/8
3 1/4	3 3/4	1/2	10	5/8	1 3/4	1 1/4	3/8	1/2	3/4	1 1/4	1/2	4 3/4	5 3/4	1/2-13	1 1/2	4 7/8	2 5/8	3 1/4	2 5/8
4	4 1/2	1/2	10	5/8	1 3/4	1 1/4	3/8	1/2	3/4	1 1/4	1/2	5 1/2	6 1/2	1/2-13	2 1/16	4 7/8	2 5/8	3 1/4	2 5/8
5	5 1/2	1/2	10	5/8	1 3/4	1 1/4	7/16	3/4	1	1 9/16	11/16	6 7/8	8 1/4	5/8-11	2 11/16	5 1/8	2 7/8	3 1/8	2 7/8
6	6 1/2	3/4	12	3/4	2	1 1/2	7/16	3/4	1	1 9/16	11/16	7 7/8	9 1/4	3/4-10	3 1/4	5 3/4	3 1/8	3 5/8	3 1/8
8	8 1/2	3/4	12	3/4	2	1 1/2	9/16	3/4	1	1 9/16	11/16	9 7/8	11 1/4	3/4-10	4 1/2	5 7/8	3 1/4	3 3/4	3 1/4

BORE	ROD DIA.	THREAD		ROD EXTENSIONS AND PILOT DIMENSIONS									ENVELOPE AND MOUNTING DIMENSIONS		
		MM	KK	CC	A	B ‡	C	D	V	W	TK	RM	XS	XT	Y
1 1/2	5/8	7/16-20	1/2-20	3/4	1 1/8	3/8	1/2	1/4	5/8	3/8	§	1 3/8	1 15/16	1 31/32	
	1†Ω	3/4-16	7/8-14	1 1/8	1 1/2	1/2	7/8	1/2	1	Φ	§	1 3/4	2 5/16	2 11/32	
2	5/8	7/16-20	1/2-20	3/4	1 1/8	3/8	1/2	1/4	5/8	1/2	§	1 3/8	1 15/16	1 31/32	
	1	3/4-16	7/8-14	1 1/8	1 1/2	1/2	7/8	1/2	1	1/2	§	1 3/4	2 5/16	2 11/32	
2 1/2	1 3/8†Ω	1-14	1 1/4-12	1 5/8	2	5/8	1 1/8	5/8	1 1/4	Φ	§	2	2 9/16	2 19/32	
	5/8	7/16-20	1/2-20	3/4	1 1/8	3/8	1/2	1/4	5/8	5/8	2 3/8	1 3/8	1 15/16	1 31/32	
	1	3/4-16	7/8-14	1 1/8	1 1/2	1/2	7/8	1/2	1	5/8	2 1/2	1 3/4	2 5/16	2 11/32	
	1 3/8	1-14	1 1/4-12	1 5/8	2	5/8	1 1/8	5/8	1 1/4	5/8	§	2	2 9/16	2 19/32	
3 1/4	1 3/4†Ω	1 1/4-12	1 1/2-12	2	2 3/8	3/4	1 1/2	3/4	1 1/2	Φ	§	2 1/4	2 13/16	2 27/32	
	1	3/4-16	7/8-14	1 1/8	1 1/2	1/2	7/8	1/4	3/4	3/4	2 1/2	1 7/8	2 7/16	2 7/16	
	1 3/8	1-14	1 1/4-12	1 5/8	2	5/8	1 1/8	3/8	1	3/4	3 7/32	2 1/8	2 11/16	2 11/16	
	1 3/4	1 1/4-12	1 1/2-12	2	2 3/8	3/4	1 1/2	1/2	1 1/4	Φ	§	2 3/8	2 15/16	2 15/16	
4	2†	1 1/2-12	1 3/4-12	2 1/4	2 5/8	7/8	1 3/4	1/2	1 3/8	Φ	§	2 1/2	3 1/16	3 1/16	
	1	3/4-16	7/8-14	1 1/8	1 1/2	1/2	7/8	1/4	3/4	3/4	2 1/2	1 7/8	2 7/16	2 7/16	
	1 3/8	1-14	1 1/4-12	1 5/8	2	5/8	1 1/8	3/8	1	3/4	3 7/32	2 1/8	2 11/16	2 11/16	
	1 3/4	1 1/4-12	1 1/2-12	2	2 3/8	3/4	1 1/2	1/2	1 1/4	3/4	3 7/8	2 3/8	2 15/16	2 15/16	
5	2	1 1/2-12	1 3/4-12	2 1/4	2 5/8	7/8	1 3/4	1/2	1 3/8	Φ	4	2 1/2	3 1/16	3 1/16	
	2 1/2†	1 7/8-12	2 1/4-12	3	3 1/8	1	2 1/8	5/8	1 5/8	Φ	§	2 3/4	3 5/16	3 5/16	
	1	3/4-16	7/8-14	1 1/8	1 1/2	1/2	7/8	1/4	3/4	1	2 1/2	2 1/16	2 7/16	2 7/16	
	1 3/8	1-14	1 1/4-12	1 5/8	2	5/8	1 1/8	3/8	1	1	3 7/32	2 5/16	2 11/16	2 11/16	
6	1 3/4	1 1/4-12	1 1/2-12	2	2 3/8	3/4	1 1/2	1/2	1 1/4	1	3 7/8	2 9/16	2 15/16	2 15/16	
	2	1 1/2-12	1 3/4-12	2 1/4	2 5/8	7/8	1 3/4	1/2	1 3/8	1	4	2 1/2	3 1/16	3 1/16	
	2 1/2	1 7/8-12	2 1/4-12	3	3 1/8	1	2 1/8	5/8	1 5/8	1	4 7/16	2 15/16	3 7/16	3 7/16	
	3	2 1/4-12	2 3/4-12	3 1/2	3 3/4	1	2 5/8	5/8	1 5/8	Φ	§	2 15/16	3 5/16	3 5/16	
8	3 1/2†	2 1/2-12	3 1/4-12	3 1/2	4 1/4	1	3	5/8	1 5/8	Φ	§	2 15/16	3 5/16	3 5/16	
	1 3/8	1-14	1 1/4-12	1 5/8	2	5/8	1 1/8	1/4	7/8	1 1/8	3 7/32	2 5/16	2 13/16	2 13/16	
	1 3/4	1 1/4-12	1 1/2-12	2	2 3/8	3/4	1 1/2	3/8	1 1/8	1 1/8	3 7/8	2 9/16	3 1/16	3 1/16	
	2	1 1/2-12	1 3/4-12	2 1/4	2 5/8	7/8	1 3/4	3/8	1 1/4	1 1/8	4	2 11/16	3 3/16	3 3/16	
8	2 1/2	1 7/8-12	2 1/4-12	3	3 1/8	1	2 1/8	1/2	1 1/2	1 1/8	4 7/16	2 15/16	3 7/16	3 7/16	
	3	2 1/4-12	2 3/4-12	3 1/2	3 3/4	1	2 5/8	1/2	1 1/2	1 1/8	5 1/4	2 15/16	3 7/16	3 7/16	
	3 1/2	2 1/2-12	3 1/4-12	3 1/2	4 1/4	1	3	1/2	1 1/2	1 1/8	5 5/8	2 15/16	3 7/16	3 7/16	
	4	3-12	3 3/4-12	4	4 3/4	1	Δ	1/2	1 1/2	Φ	§	2 15/16	3 7/16	3 7/16	
8	1 3/8	1-14	1 1/4-12	1 5/8	2	5/8	1 1/8	1/4	7/8	1 1/8	3 7/32	2 5/16	2 13/16	2 13/16	
	1 3/4	1 1/4-12	1 1/2-12	2	2 3/8	3/4	1 1/2	3/8	1 1/8	1 1/8	3 7/8	2 9/16	3 1/16	3 1/16	
	2	1 1/2-12	1 3/4-12	2 1/4	2 5/8	7/8	1 3/4	3/8	1 1/4	1 1/8	4	2 11/16	3 3/16	3 3/16	
	2 1/2	1 7/8-12	2 1/4-12	3	3 1/8	1	2 1/8	1/2	1 1/2	1 1/8	4 7/16	2 15/16	3 7/16	3 7/16	
8	3	2 1/4-12	2 3/4-12	3 1/2	3 3/4	1	2 5/8	1/2	1 1/2	1 1/8	5 1/4	2 15/16	3 7/16	3 7/16	
	3 1/2	2 1/2-12	3 1/4-12	3 1/2	4 1/4	1	3	1/2	1 1/2	1 1/8	5 5/8	2 15/16	3 7/16	3 7/16	
	4	3-12	3 3/4-12	4	4 3/4	1	Δ	1/2	1 1/2	1 1/8	6 7/16	2 15/16	3 7/16	3 7/16	
	4 1/2	3 1/4-12	4 1/4-12	4 1/2	5 1/4	1	Δ	1/2	1 1/2	1 1/8	7 1/8	2 15/16	3 7/16	3 7/16	
8	5	3 1/2-12	4 3/4-12	5	5 3/4	1	Δ	1/2	1 1/2	1 1/8	7 5/8	2 15/16	3 7/16	3 7/16	

† HEAD END PORTS SHALLOW TAPPED

Ω FIXED CUSHIONS FURNISHED AT THE HEAD END IN THESE SIZES

Δ (4) SPANNER HOLES USED INSTEAD OF FLATS ON 4" DIA. AND LARGER RODS

§ THESE CYLINDERS HAVE FULL PLATE RETAINERS. USE "E" DIMENSION INSTEAD OF "RM" - SEE PAGE 42

‡ B DIMENSION TOLERANCE -.001/- .003

* SS DIMENSION CHANGES ON DOUBLE ROD CYLINDERS - SEE PAGE 72 FOR DETAILS

NOTE: SUGGESTED THAT THESE MOUNTS BE KEYED OR PINNED TO PREVENT SHIFTING - SEE PAGE 73

Φ CONSULT FACTORY FOR THREAD DEPTH



1 1/2 THRU 8 BORE • SERIES A4/L4/H4

BIG BORE CYLINDERS ON NEXT PAGE

SIDE LUGS MOUNT

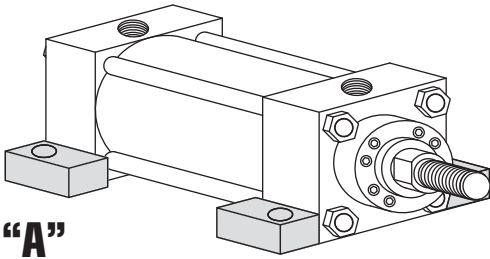

"A"
YATES STYLE A
NFPA-MS2

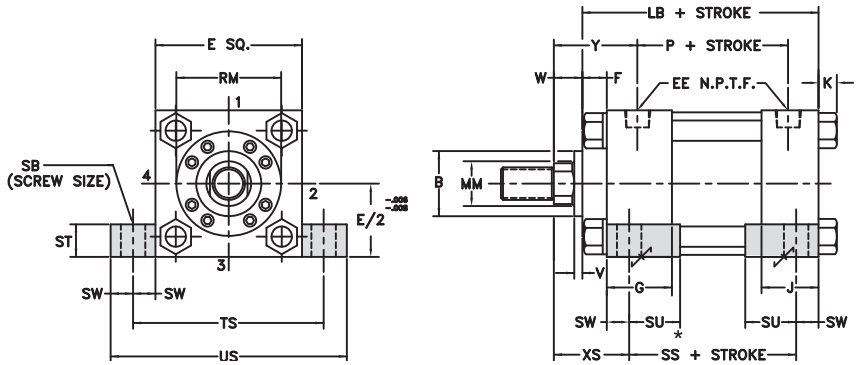

SIDE TAPPED MOUNT

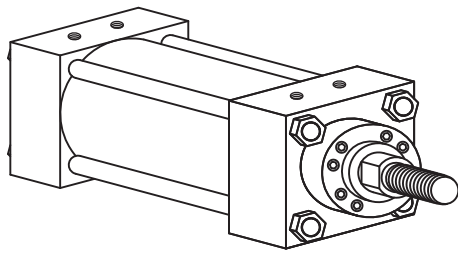

"B"
YATES STYLE B
NFPA-MS4

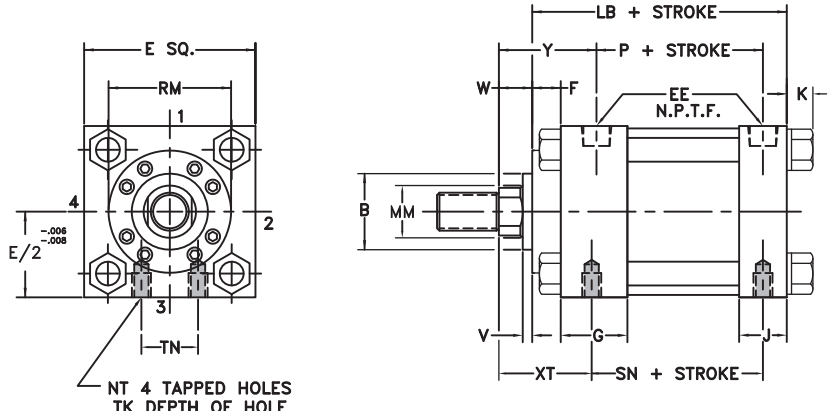

CENTER-LINE LUGS MOUNT

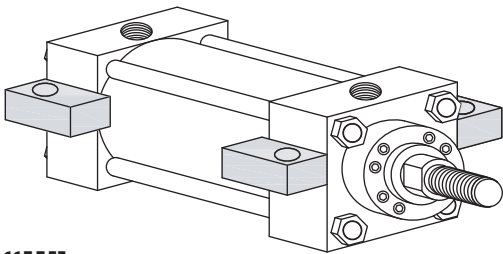

"H"
YATES STYLE H
NFPA-MS3

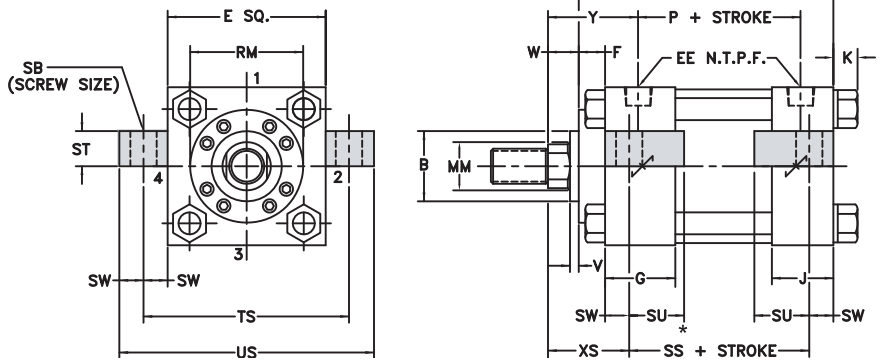

STANDARD ROD ENDS

#2 STD MALE
NFPA-SM

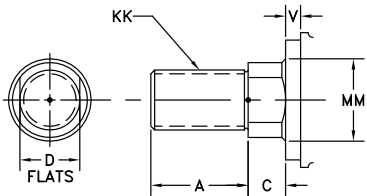

#4 STD FEMALE
NFPA-SF

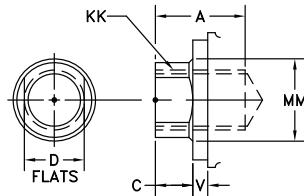

#1 MALE
NFPA-IM

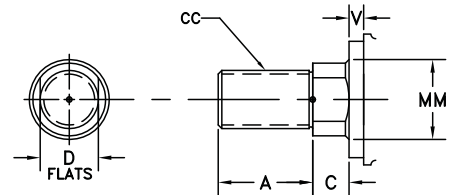

BORE	SAE															ADD STROKE			
	E	EE	OPT	F	G	J	K	SB	ST	SU	SW	TS	US	NT	TN	LB	P	SS *	SN
10	10 5/8	1	16	3/4	2 1/4	2	11/16	1	1 1/4	2	7/8	12 3/8	14 1/8	1-8	5 1/2	7 1/8	4 1/8	4 5/8	4 1/8
12	12 3/4	1	16	3/4	2 1/4	2	11/16	1	1 1/4	2	7/8	14 1/2	16 1/4	1-8	7 1/4	7 5/8	4 5/8	5 1/8	4 5/8
14	14 3/4	1 1/4	20	3/4	2 3/4	2 1/4	13/16	1 1/4	1 1/2	2 1/2	1 1/8	17	19 1/4	1 1/4-7	8 3/8	8 7/8	5 1/2	5 7/8	5 1/2
16	17 1/2	1 1/2	24	3/4	2 15/16	2 15/16	15/16	1 3/4	2	3 1/2	1 3/4	21	24 1/4	1 3/4-12	7	10	6 1/2	5 3/4	6 1/2
18	19 1/2	1 1/2	24	7/8	3 7/16	3 7/16	1	2	2 1/2	3 1/2	2	23 1/2	27 1/2	2-12	8	11 1/8	6 1/2	6 1/4	7
20	21 3/4	2	32	7/8	3 15/16	3 15/16	1 1/8	2 1/4	3	3 5/8	2 3/8	26 1/2	31 1/4	2 1/4-12	8 1/2	12 5/8	7 3/8	7	7 3/4

BORE	ROD DIA.	THREAD		ROD EXTENSIONS AND PILOT DIMENSIONS									ENVELOPE AND MOUNTING DIMENSIONS		
		MM	KK	CC	A	B ‡	C	D	V	W	TK	RM	XS	XT	Y
10	1 3/4	1 1/4-12	1 1/2-12	2	2 3/8	3/4	1 1/2	3/8	1 1/8	1 1/2	3 7/8	2 3/4	3 1/8	3 1/8	
	2	1 1/2-12	1 3/4-12	2 1/4	2 5/8	7/8	1 3/4	3/8	1 1/4	1 1/2	4	2 7/8	3 1/4	3 1/4	
	2 1/2	1 7/8-12	2 1/4-12	3	3 1/8	1	2 1/8	1/2	1 1/2	1 1/2	4 7/16	3 1/8	3 1/2	3 1/2	
	3	2 1/4-12	2 3/4-12	3 1/2	3 3/4	1	2 5/8	1/2	1 1/2	1 1/2	5 1/4	3 1/8	3 1/2	3 1/2	
	3 1/2	2 1/2-12	3 1/4-12	3 1/2	4 1/4	1	3	1/2	1 1/2	1 1/2	5 5/8	3 1/8	3 1/2	3 1/2	
	4	3-12	3 3/4-12	4	4 3/4	1	Δ	1/2	1 1/2	1 1/2	6 7/16	3 1/8	3 1/2	3 1/2	
	4 1/2	3 1/4-12	4 1/4-12	4 1/2	5 1/4	1	Δ	1/2	1 1/2	1 1/2	7 1/8	3 1/8	3 1/2	3 1/2	
	5	3 1/2-12	4 3/4-12	5	5 3/4	1	Δ	1/2	1 1/2	1 1/2	7 5/8	3 1/8	3 1/2	3 1/2	
5 1/2	4-12	5 1/4-12	5 1/2	6 1/4	1	Δ	1/2	1 1/2	1 1/2	8 3/8	3 1/8	3 1/2	3 1/2		
12	2	1 1/2-12	1 3/4-12	2 1/4	2 5/8	7/8	1 3/4	3/8	1 1/4	1 1/2	4	2 7/8	3 1/4	3 1/4	
	2 1/2	1 7/8-12	2 1/4-12	3	3 1/8	1	2 1/8	1/2	1 1/2	1 1/2	4 7/16	3 1/8	3 1/2	3 1/2	
	3	2 1/4-12	2 3/4-12	3 1/2	3 3/4	1	2 5/8	1/2	1 1/2	1 1/2	5 1/4	3 1/8	3 1/2	3 1/2	
	3 1/2	2 1/2-12	3 1/4-12	3 1/2	4 1/4	1	3	1/2	1 1/2	1 1/2	5 5/8	3 1/8	3 1/2	3 1/2	
	4	3-12	3 3/4-12	4	4 3/4	1	Δ	1/2	1 1/2	1 1/2	6 7/16	3 1/8	3 1/2	3 1/2	
	4 1/2	3 1/4-12	4 1/4-12	4 1/2	5 1/4	1	Δ	1/2	1 1/2	1 1/2	7 1/8	3 1/8	3 1/2	3 1/2	
	5	3 1/2-12	4 3/4-12	5	5 3/4	1	Δ	1/2	1 1/2	1 1/2	7 5/8	3 1/8	3 1/2	3 1/2	
	5 1/2	4-12	5 1/4-12	5 1/2	6 1/4	1	Δ	1/2	1 1/2	1 1/2	8 3/8	3 1/8	3 1/2	3 1/2	
14	2 1/2	1 7/8-12	2 1/4-12	3	3 1/8	1	2 1/8	1/2	1 1/2	1 7/8	4 7/16	3 3/8	3 13/16	3 13/16	
	3	2 1/4-12	2 3/4-12	3 1/2	3 3/4	1	2 5/8	1/2	1 1/2	1 7/8	5 1/4	3 3/8	3 13/16	3 13/16	
	3 1/2	2 1/2-12	3 1/4-12	3 1/2	4 1/4	1	3	1/2	1 1/2	1 7/8	5 5/8	3 3/8	3 13/16	3 13/16	
	4	3-12	3 3/4-12	4	4 3/4	1	Δ	1/2	1 1/2	1 7/8	6 7/16	3 3/8	3 13/16	3 13/16	
	4 1/2	3 1/4-12	4 1/4-12	4 1/2	5 1/4	1	Δ	1/2	1 1/2	1 7/8	7 1/8	3 3/8	3 13/16	3 13/16	
	5	3 1/2-12	4 3/4-12	5	5 3/4	1	Δ	1/2	1 1/2	1 7/8	7 5/8	3 3/8	3 13/16	3 13/16	
	5 1/2	4-12	5 1/4-12	5 1/2	6 1/4	1	Δ	1/2	1 1/2	1 7/8	8 3/8	3 3/8	3 13/16	3 13/16	
	16	3 1/2	2 1/2-12	3 1/4-12	3 1/2	4 1/4	1	3	1/2	1 1/2	3	5 5/8	4	3 11/16	3 5/8
4	3-12	3 3/4-12	4	4 3/4	1	Δ	1/2	1 1/2	3	6 7/16	4	3 11/16	3 5/8		
4 1/2	3 1/4-12	4 1/4-12	4 1/2	5 1/4	1	Δ	1/2	1 1/2	3	7 1/8	4	3 11/16	3 5/8		
5	3 1/2-12	4 3/4-12	5	5 3/4	1	Δ	1/2	1 1/2	3	7 5/8	4	3 11/16	3 5/8		
5 1/2	4-12	5 1/4-12	5 1/2	6 1/4	1	Δ	1/2	1 1/2	3	8 3/8	4	3 11/16	3 5/8		
18	4	3-12	3 3/4-12	4	4 3/4	1	Δ	3/8	1 3/8	3 1/4	6 7/16	4 1/4	3 15/16	4 1/8	
	4 1/2	3 1/4-12	4 1/4-12	4 1/2	5 1/4	1	Δ	3/8	1 3/8	3 1/4	7 1/8	4 1/4	3 15/16	4 1/8	
	5	3 1/2-12	4 3/4-12	5	5 3/4	1	Δ	3/8	1 3/8	3 1/4	7 5/8	4 1/4	3 15/16	4 1/8	
	5 1/2	4-12	5 1/4-12	5 1/2	6 1/4	1	Δ	3/8	1 3/8	3 1/4	8 3/8	4 1/4	3 15/16	4 1/8	
20	4	3-12	3 3/4-12	4	4 3/4	1	Δ	3/8	1 3/8	3 3/4	6 7/16	4 5/8	4 3/16	4 7/16	
	4 1/2	3 1/4-12	4 1/4-12	4 1/2	5 1/4	1	Δ	3/8	1 3/8	3 3/4	7 1/8	4 5/8	4 3/16	4 7/16	
	5	3 1/2-12	4 3/4-12	5	5 3/4	1	Δ	3/8	1 3/8	3 3/4	7 5/8	4 5/8	4 3/16	4 7/16	
	5 1/2	4-12	5 1/4-12	5 1/2	6 1/4	1	Δ	3/8	1 3/8	3 3/4	8 3/8	4 5/8	4 3/16	4 7/16	

† HEAD END PORTS SHALLOW TAPPED
Ω FIXED CUSHIONS FURNISHED AT THE HEAD END IN THESE SIZES
Δ (4) SPANNER HOLES USED INSTEAD OF FLATS ON 4" DIA. AND LARGER RODS
§ THESE CYLINDERS HAVE FULL PLATE RETAINERS. USE "E" DIMENSION INSTEAD OF "RM" - SEE PAGE 42
‡ B DIMENSION TOLERANCE -.001/-.003
* SS DIMENSION CHANGES ON DOUBLE ROD CYLINDERS - SEE PAGE 72 FOR DETAILS
NOTE: SUGGESTED THAT THESE MOUNTS BE KEYED OR PINNED TO PREVENT SHIFTING - SEE PAGE 73



SIDE END LUGS MOUNT

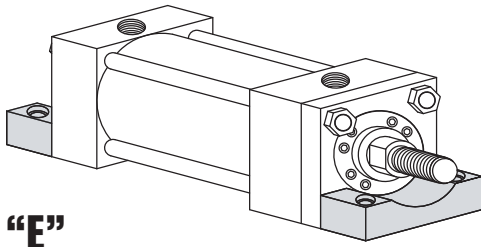

“E”
YATES STYLE E
NFPA-MS7

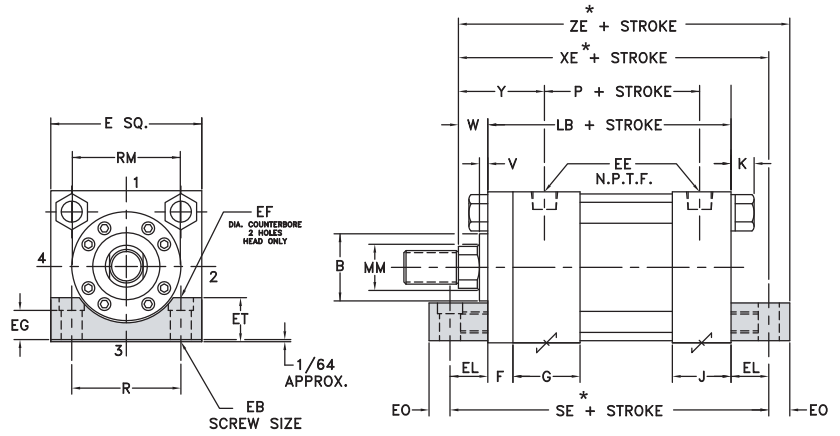

BORE	SAE														ADD STROKE		
	E	EE	OPT	F	G	J	K	EB	EF	EG	EL	EO	ET	R	LB	SE*	P
1 1/2	2	3/8	6	3/8	1 1/2	1	1/4	1/4	1/2	7/16	3/4	1/4	9/16	1.43	4	5 1/2	2 3/16
2	2 1/2	3/8	6	3/8	1 1/2	1	5/16	5/16	1/2	15/32	15/16	5/16	3/4	1.84	4	5 7/8	2 3/16
2 1/2	3	3/8	6	3/8	1 1/2	1	5/16	5/16	1/2	5/8	1 1/16	5/16	7/8	2.19	4 1/8	6 1/4	2 5/16
3 1/4	3 3/4	1/2	10	5/8	1 3/4	1 1/4	3/8	3/8	19/32	11/16	7/8	3/8	1	2.76	4 7/8	6 5/8	2 5/8
4	4 1/2	1/2	10	5/8	1 3/4	1 1/4	3/8	3/8	NA	NA	1	3/8	1 1/4	3.32	4 7/8	6 7/8	2 5/8
5	5 1/2	1/2	10	5/8	1 3/4	1 1/4	7/16	1/2	7/8	1 1/4	1 1/16	1/2	1 1/2	4.10	5 1/8	7 1/4	2 7/8
6	6 1/2	3/4	12	3/4	2	1 1/2	7/16	1/2	7/8	1 1/4	1	1/2	1 5/8	4.88	5 3/4	7 3/4	3 1/8

BORE	ROD DIA.	ROD EXTENSIONS AND PILOT DIMENSIONS											ADD STROKE	
	MM	KK	CC	A	B †	C	D	V	W	RM	Y	XE *	ZE *	
1 1/2	5/8	7/16-20	1/2-20	3/4	1 1/8	3/8	1/2	1/4	5/8	§	1 31/32	5 3/8	5 5/8	
	1 † Ω	3/4-16	7/8-14	1 1/8	1 1/2	1/2	7/8	1/2	1	§	2 11/32	5 3/4	6	
2	5/8	7/16-20	1/2-20	3/4	1 1/8	3/8	1/2	1/4	5/8	§	1 31/32	5 9/16	5 7/8	
	1	3/4-16	7/8-14	1 1/8	1 1/2	1/2	7/8	1/2	1	§	2 11/32	5 15/16	6 1/4	
	1 3/8 † Ω	1-14	1 1/4-12	1 5/8	2	5/8	1 1/8	5/8	1 1/4	§	2 19/32	6 3/16	6 1/2	
2 1/2	5/8	7/16-20	1/2-20	3/4	1 1/8	3/8	1/2	1/4	5/8	2 3/8	1 31/32	5 13/16	6 1/8	
	1	3/4-16	7/8-14	1 1/8	1 1/2	1/2	7/8	1/2	1	2 1/2	2 11/32	6 3/16	6 1/2	
	1 3/8	1-14	1 1/4-12	1 5/8	2	5/8	1 1/8	5/8	1 1/4	§	2 19/32	6 7/16	6 3/4	
	1 3/4 † Ω	1 1/4-12	1 1/2-12	2	2 3/8	3/4	1 1/2	3/4	1 1/2	§	2 27/32	6 11/16	7	
3 1/4	1	3/4-16	7/8-14	1 1/8	1 1/2	1/2	7/8	1/4	3/4	2 1/2	2 7/16	6 1/2	6 7/8	
	1 3/8	1-14	1 1/4-12	1 5/8	2	5/8	1 1/8	3/8	1	3 7/32	2 11/16	6 3/4	7 1/8	
	1 3/4	1 1/4-12	1 1/2-12	2	2 3/8	3/4	1 1/2	1/2	1 1/4	§	2 15/16	7	7 3/8	
	2 †	1 1/2-12	1 3/4-12	2 1/4	2 5/8	7/8	1 3/4	1/2	1 3/8	§	3 1/16	7 1/8	7 1/2	
	4	3/4-16	7/8-14	1 1/8	1 1/2	1/2	7/8	1/4	3/4	2 1/2	2 7/16	6 5/8	7	
4	1 3/8	1-14	1 1/4-12	1 5/8	2	5/8	1 1/8	3/8	1	3 7/32	2 11/16	6 7/8	7 1/4	
	1 3/4	1 1/4-12	1 1/2-12	2	2 3/8	3/4	1 1/2	1/2	1 1/4	3 7/8	2 15/16	7 1/8	7 1/2	
	2	1 1/2-12	1 3/4-12	2 1/4	2 5/8	7/8	1 3/4	1/2	1 3/8	4	3 1/16	7 1/4	7 5/8	
	2 1/2 †	1 7/8-12	2 1/4-12	3	3 1/8	1	2 1/8	5/8	1 5/8	§	3 5/16	7 1/2	7 7/8	
	1	3/4-16	7/8-14	1 1/8	1 1/2	1/2	7/8	1/4	3/4	2 1/2	2 7/16	6 15/16	7 7/16	
	1 3/8	1-14	1 1/4-12	1 5/8	2	5/8	1 1/8	3/8	1	3 7/32	2 11/16	7 3/16	7 11/16	
	1 3/4	1 1/4-12	1 1/2-12	2	2 3/8	3/4	1 1/2	1/2	1 1/4	3 7/8	2 15/16	7 7/16	7 15/16	
	2	1 1/2-12	1 3/4-12	2 1/4	2 5/8	7/8	1 3/4	1/2	1 3/8	4	3 1/16	7 9/16	8 1/16	
5	2 1/2	1 7/8-12	2 1/4-12	3	3 1/8	1	2 1/8	5/8	1 5/8	4 7/16	3 5/16	7 13/16	8 5/16	
	3	2 1/4-12	2 3/4-12	3 1/2	3 3/4	1	2 5/8	5/8	1 5/8	§	3 5/16	7 13/16	8 5/16	
	3 1/2 †	2 1/2-12	3 1/4-12	3 1/2	4 1/4	1	3	5/8	1 5/8	§	3 5/16	7 13/16	8 5/16	
	1 3/8	1-14	1 1/4-12	1 5/8	2	5/8	1 1/8	1/4	7/8	3 7/32	2 13/16	7 5/8	8 1/8	
	1 3/4	1 1/4-12	1 1/2-12	2	2 3/8	3/4	1 1/2	3/8	1 1/8	3 7/8	3 1/16	7 7/8	8 3/8	
6	2	1 1/2-12	1 3/4-12	2 1/4	2 5/8	7/8	1 3/4	3/8	1 1/4	4	3 3/16	8	8 1/2	
	2 1/2	1 7/8-12	2 1/4-12	3	3 1/8	1	2 1/8	1/2	1 1/2	4 7/16	3 7/16	8 1/4	8 3/4	
	3	2 1/4-12	2 3/4-12	3 1/2	3 3/4	1	2 5/8	1/2	1 1/2	5 1/4	3 7/16	8 1/4	8 3/4	
	3 1/2	2 1/2-12	3 1/4-12	3 1/2	4 1/4	1	3	1/2	1 1/2	5 5/8	3 7/16	8 1/4	8 3/4	
	4	3-12	3 3/4-12	4	4 3/4	1	Δ	1/2	1 1/2	§	3 7/16	8 1/4	8 3/4	



STANDARD ROD ENDS

#2 STD MALE NFPA-SM

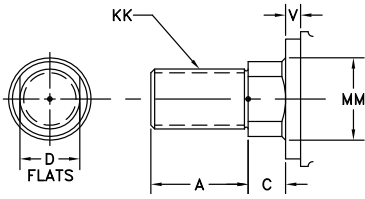

#4 STD FEMALE NFPA-SF

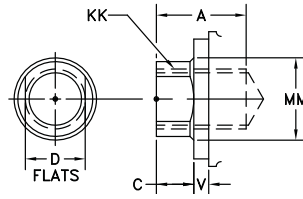

#1 MALE NFPA-IM

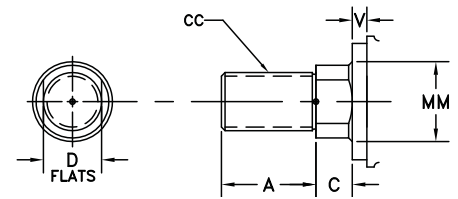

BORE	SAE														ADD STROKE		
	E	EE	OPT	F	G	J	K	EB	EF	EG	EL	EO	ET	R	LB	SE*	P
8	8 1/2	3/4	12	3/4	2	1 1/2	9/16	5/8	NA	NA	1 1/8	5/8	2	6.44	5 7/8	7 3/8	3 1/4
10	10 5/8	1	16	3/4	2 1/4	2	11/16	3/4	NA	NA	1 5/16	5/8	2 3/4	7.92	7 1/8	9	4 1/8
12	12 3/4	1	16	3/4	2 1/4	2	11/16	3/4	NA	NA	1 5/16	5/8	3 7/16	9.40	7 5/8	9 1/2	4 5/8
14	14 3/4	1 1/4	20	3/4	2 3/4	2 1/4	13/16	7/8	NA	NA	1 1/2	3/4	3 7/8	10.90	8 7/8	11 1/8	5 1/2

BORE	ROD DIA.	ROD EXTENSIONS AND PILOT DIMENSIONS											ADD STROKE	
	MM	KK	CC	A	B	C	D	V	W	RM	Y	XE*	ZE*	
8	1 3/8	1-14	1 1/4-12	1 5/8	2	5/8	1 1/8	1/4	7/8	3 7/32	2 13/16	7 7/8	8 1/2	
	1 3/4	1 1/4-12	1 1/2-12	2	2 3/8	3/4	1 1/2	3/8	1 1/8	3 7/8	3 1/16	8 1/8	8 3/4	
	2	1 1/2-12	1 3/4-12	2 1/4	2 5/8	7/8	1 3/4	3/8	1 1/4	4	3 3/16	8 1/4	8 7/8	
	2 1/2	1 7/8-12	2 1/4-12	3	3 1/8	1	2 1/8	1/2	1 1/2	4 7/16	3 7/16	8 1/2	9 1/8	
	3	2 1/4-12	2 3/4-12	3 1/2	3 3/4	1	2 5/8	1/2	1 1/2	5 1/4	3 7/16	8 1/2	9 1/8	
	3 1/2	2 1/2-12	3 1/4-12	3 1/2	4 1/4	1	3	1/2	1 1/2	5 5/8	3 7/16	8 1/2	9 1/8	
	4	3-12	3 3/4-12	4	4 3/4	1	Δ	1/2	1 1/2	6 7/16	3 7/16	8 1/2	9 1/8	
10	4 1/2	3 1/4-12	4 1/4-12	4 1/2	5 1/4	1	Δ	1/2	1 1/2	7 1/8	3 7/16	8 1/2	9 1/8	
	5	3 1/2-12	4 3/4-12	5	5 3/4	1	Δ	1/2	1 1/2	7 5/8	3 7/16	8 1/2	9 1/8	
	1 3/4	1 1/4-12	1 1/2-12	2	2 3/8	3/4	1 1/2	3/8	1 1/8	3 7/8	3 1/8	9 9/16	10 3/16	
	2	1 1/2-12	1 3/4-12	2 1/4	2 5/8	7/8	1 3/4	3/8	1 1/4	4	3 1/4	9 11/16	10 5/16	
	2 1/2	1 7/8-12	2 1/4-12	3	3 1/8	1	2 1/8	1/2	1 1/2	4 7/16	3 1/2	9 15/16	10 9/16	
	3	2 1/4-12	2 3/4-12	3 1/2	3 3/4	1	2 5/8	1/2	1 1/2	5 1/4	3 1/2	9 15/16	10 9/16	
	3 1/2	2 1/2-12	3 1/4-12	3 1/2	4 1/4	1	3	1/2	1 1/2	5 5/8	3 1/2	9 15/16	10 9/16	
12	4	3-12	3 3/4-12	4	4 3/4	1	Δ	1/2	1 1/2	6 7/16	3 1/2	9 15/16	10 9/16	
	4 1/2	3 1/4-12	4 1/4-12	4 1/2	5 1/4	1	Δ	1/2	1 1/2	7 1/8	3 1/2	9 15/16	10 9/16	
	5	3 1/2-12	4 3/4-12	5	5 3/4	1	Δ	1/2	1 1/2	7 5/8	3 1/2	9 15/16	10 9/16	
	5 1/2	4-12	5 1/4-12	5 1/2	6 1/4	1	Δ	1/2	1 1/2	8 3/8	3 1/2	9 15/16	10 9/16	
	2	1 1/2-12	1 3/4-12	2 1/4	2 5/8	7/8	1 3/4	3/8	1 1/4	4	3 1/4	10 3/16	10 13/16	
	2 1/2	1 7/8-12	2 1/4-12	3	3 1/8	1	2 1/8	1/2	1 1/2	4 7/16	3 1/2	10 7/16	11 1/16	
	3	2 1/4-12	2 3/4-12	3 1/2	3 3/4	1	2 5/8	1/2	1 1/2	5 1/4	3 1/2	10 7/16	11 1/16	
14	3 1/2	2 1/2-12	3 1/4-12	3 1/2	4 1/4	1	3	1/2	1 1/2	5 5/8	3 1/2	10 7/16	11 1/16	
	4	3-12	3 3/4-12	4	4 3/4	1	Δ	1/2	1 1/2	6 7/16	3 1/2	10 7/16	11 1/16	
	4 1/2	3 1/4-12	4 1/4-12	4 1/2	5 1/4	1	Δ	1/2	1 1/2	7 1/8	3 1/2	10 7/16	11 1/16	
	5	3 1/2-12	4 3/4-12	5	5 3/4	1	Δ	1/2	1 1/2	7 5/8	3 1/2	10 7/16	11 1/16	
	5 1/2	4-12	5 1/4-12	5 1/2	6 1/4	1	Δ	1/2	1 1/2	8 3/8	3 1/2	10 7/16	11 1/16	
	2 1/2	1 7/8-12	2 1/4-12	3	3 1/8	1	2 1/8	1/2	1 1/2	4 7/16	3 13/16	11 7/8	12 5/8	
	3	2 1/4-12	2 3/4-12	3 1/2	3 3/4	1	2 5/8	1/2	1 1/2	5 1/4	3 13/16	11 7/8	12 5/8	
14	3 1/2	2 1/2-12	3 1/4-12	3 1/2	4 1/4	1	3	1/2	1 1/2	5 5/8	3 13/16	11 7/8	12 5/8	
	4	3-12	3 3/4-12	4	4 3/4	1	Δ	1/2	1 1/2	6 7/16	3 13/16	11 7/8	12 5/8	
	4 1/2	3 1/4-12	4 1/4-12	4 1/2	5 1/4	1	Δ	1/2	1 1/2	7 1/8	3 13/16	11 7/8	12 5/8	
	5	3 1/2-12	4 3/4-12	5	5 3/4	1	Δ	1/2	1 1/2	7 5/8	3 13/16	11 7/8	12 5/8	
	5 1/2	4-12	5 1/4-12	5 1/2	6 1/4	1	Δ	1/2	1 1/2	8 3/8	3 13/16	11 7/8	12 5/8	

† HEAD END PORTS SHALLOW TAPPED
 Ω FIXED CUSHIONS FURNISHED AT THE HEAD END IN THESE SIZES
 Δ (4) SPANNER HOLES USED INSTEAD OF FLATS ON 4" DIA. AND LARGER RODS
 ■ MOUNT "E" NOT AVAILABLE WITH STD DIMENSIONS.
 § THESE CYLINDERS HAVE FULL PLATE RETAINERS. USE "E" DIMENSION INSTEAD OF "RM" - SEE PAGE 42
 ‡ B DIMENSION TOLERANCE -.001/-.003
 * SE, XE & ZE DIMENSION CHANGES ON DOUBLE ROD CYLINDERS - SEE PAGE 72 FOR DETAILS

NOTE: SUGGESTED THAT THESE MOUNTS BE KEYPED OR PINNED TO PREVENT SHIFTING - SEE PAGE 73
NOTE: BOTTOMS OF HEAD AND CAP ARE MOUNTING SURFACES. LUGS HOLD CYLINDER AGAINST MOUNTING SURFACE
NOTE: CHECK FOR CLEARANCE BETWEEN FRONT MOUNTING LUG AND ROD END ATTACHMENT. SPECIFY LONGER THAN STANDARD "W" DIMENSION IF NECESSARY.



SPHERICAL BEARING MOUNT

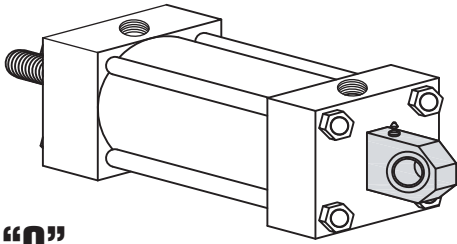

“Q”
YATES STYLE Q
 NFPA-MPU3

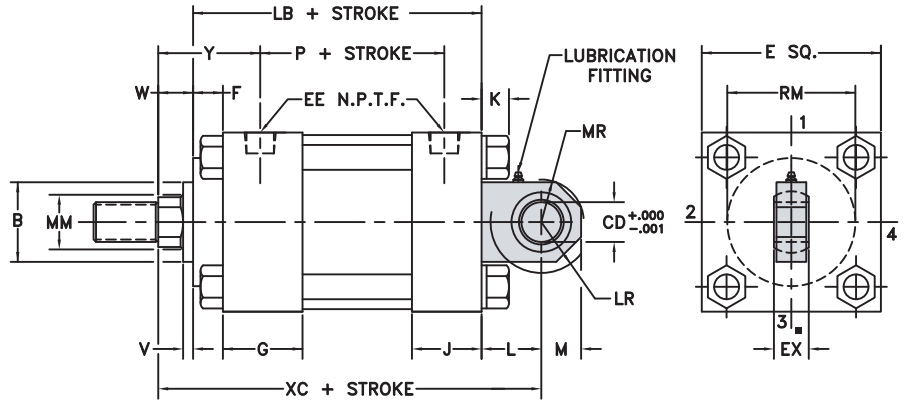

BORE	SAE													ADD STROKE	
	E	EE	OPT	F	G	J	K	CD	EX ^a	L	LR	M	MR	LB	P
1 1/2	2	3/8	6	3/8	1 1/2	1	1/4	1/2	7/16	3/4	5/8	3/4	13/16	4	2 3/16
2	2 1/2	3/8	6	3/8	1 1/2	1	5/16	1/2	7/16	3/4	5/8	3/4	13/16	4	2 3/16
2 1/2	3	3/8	6	3/8	1 1/2	1	5/16	1/2	7/16	3/4	5/8	3/4	13/16	4 1/8	2 5/16
3 1/4	3 3/4	1/2	10	5/8	1 3/4	1 1/4	3/8	3/4	21/32	1 1/4	1	1	1 1/8	4 7/8	2 5/8
4	4 1/2	1/2	10	5/8	1 3/4	1 1/4	3/8	3/4	21/32	1 1/4	1	1	1 1/8	4 7/8	2 5/8
5	5 1/2	1/2	10	5/8	1 3/4	1 1/4	7/16	3/4	21/32	1 1/4	1	1	1 1/8	5 1/8	2 7/8
6	6 1/2	3/4	12	3/4	2	1 1/2	7/16	1	7/8	1 1/2	1 1/4	1 1/4	1 3/8	5 3/4	3 1/8

BORE	ROD DIA.	ROD EXTENSIONS AND PILOT DIMENSIONS										ADD STROKE	MAX. PSI
		MM	KK	CC	A	B \ddagger	C	D	V	W	Y		
1 1/2	5/8	7/16-20	1/2-20	3/4	1 1/8	3/8	1/2	1/4	5/8	1 31/32	§	5 3/8	1675
	1†Ω	3/4-16	7/8-14	1 1/8	1 1/2	1/2	7/8	1/2	1	2 11/32	§	5 3/4	
2	5/8	7/16-20	1/2-20	3/4	1 1/8	3/8	1/2	1/4	5/8	1 31/32	§	5 3/8	950
	1	3/4-16	7/8-14	1 1/8	1 1/2	1/2	7/8	1/2	1	2 11/32	§	5 3/4	
2 1/2	1 3/8†Ω	1-14	1 1/4-12	1 5/8	2	5/8	1 1/8	5/8	1 1/4	2 19/32	§	6	610
	5/8	7/16-20	1/2-20	3/4	1 1/8	3/8	1/2	1/4	5/8	1 31/32	2 3/8	5 1/2	
	1	3/4-16	7/8-14	1 1/8	1 1/2	1/2	7/8	1/2	1	2 11/32	2 1/2	5 7/8	
3 1/4	1 3/8	1-14	1 1/4-12	1 5/8	2	5/8	1 1/8	5/8	1 1/4	2 19/32	§	6 1/8	840
	1 3/4	1 1/4-12	1 1/2-12	2	2 3/8	3/4	1 1/2	3/4	1 1/2	2 27/32	§	6 3/8	
	1	3/4-16	7/8-14	1 1/8	1 1/2	1/2	7/8	1/4	3/4	2 7/16	2 1/2	6 7/8	
	2†	1 1/2-12	1 3/4-12	2 1/4	2 5/8	7/8	1 3/4	1/2	1 3/8	3 1/16	§	7 1/2	
4	1	3/4-16	7/8-14	1 1/8	1 1/2	1/2	7/8	1/4	3/4	2 7/16	2 1/2	6 7/8	555
	1 3/8	1-14	1 1/4-12	1 5/8	2	5/8	1 1/8	3/8	1	2 11/16	3 7/32	7 1/8	
	1 3/4	1 1/4-12	1 1/2-12	2	2 3/8	3/4	1 1/2	1/2	1 1/4	2 15/16	3 7/8	7 3/8	
5	2	1 1/2-12	1 3/4-12	2 1/4	2 5/8	7/8	1 3/4	1/2	1 3/8	3 1/16	4	7 1/2	360
	2 1/2†	1 7/8-12	2 1/4-12	3	3 1/8	1	2 1/8	5/8	1 5/8	3 5/16	§	7 3/4	
	1	3/4-16	7/8-14	1 1/8	1 1/2	1/2	7/8	1/4	3/4	2 7/16	2 1/2	7 1/8	
	1 3/8	1-14	1 1/4-12	1 5/8	2	5/8	1 1/8	3/8	1	2 11/16	3 7/32	7 3/8	
	1 3/4	1 1/4-12	1 1/2-12	2	2 3/8	3/4	1 1/2	1/2	1 1/4	2 15/16	3 7/8	7 5/8	
	2	1 1/2-12	1 3/4-12	2 1/4	2 5/8	7/8	1 3/4	1/2	1 3/8	3 1/16	4	7 3/4	
	2 1/2	1 7/8-12	2 1/4-12	3	3 1/8	1	2 1/8	5/8	1 5/8	3 5/16	4 7/16	8	
6	3	2 1/4-12	2 3/4-12	3 1/2	3 3/4	1	2 5/8	5/8	1 5/8	3 5/16	§	8	440
	3 1/2†	2 1/2-12	3 1/4-12	3 1/2	4 1/4	1	3	5/8	1 5/8	3 5/16	§	8	
	1 3/8	1-14	1 1/4-12	1 5/8	2	5/8	1 1/8	1/4	7/8	2 13/16	3 7/32	8 1/8	
	1 3/4	1 1/4-12	1 1/2-12	2	2 3/8	3/4	1 1/2	3/8	1 1/8	3 1/16	3 7/8	8 3/8	
	2	1 1/2-12	1 3/4-12	2 1/4	2 5/8	7/8	1 3/4	3/8	1 1/4	3 3/16	4	8 1/2	
	2 1/2	1 7/8-12	2 1/4-12	3	3 1/8	1	2 1/8	1/2	1 1/2	3 7/16	4 7/16	8 3/4	



STANDARD ROD ENDS

#2 STD MALE NFFPA-SM

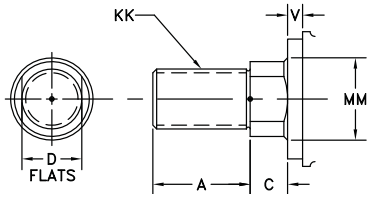

#4 STD FEMALE NFFPA-SF

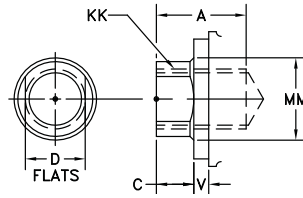

#1 MALE NFFPA-IM

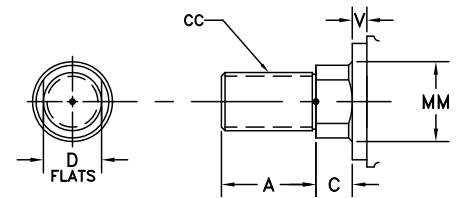

BORE	SAE													ADD STROKE	
	E	EE	OPT	F	G	J	K	CD	EX [†]	L	LR	M	MR	LB	P
8	8 1/2	3/4	12	3/4	2	1 1/2	9/16	1	7/8	1 1/2	1 5/16	1 1/4	1 3/8	5 7/8	3 1/4
10	10 5/8	1	16	3/4	2 1/4	2	11/16	1 3/8	1 3/16	2 1/8	1 13/16	1 7/8	2 1/16	7 1/8	4 1/8
12	12 3/4	1	16	3/4	2 1/4	2	11/16	1 3/4	1 17/32	2 1/4	1 15/16	2 1/2	2 3/4	7 5/8	4 5/8
14	14 3/4	1 1/4	20	3/4	2 3/4	2 1/4	13/16	2	1 3/4	2 1/2	2 3/16	2 1/2	2 3/4	8 7/8	5 1/2

BORE	ROD DIA. MM	ROD EXTENSIONS AND PILOT DIMENSIONS											ADD STROKE XC	MAX. PSI
		KK	CC	A	B [‡]	C	D	V	W	Y	RM			
8	1 3/8	1-14	1 1/4-12	1 5/8	2	5/8	1 1/8	1/4	7/8	2 13/16	3 7/32	8 1/4	250	
	1 3/4	1 1/4-12	1 1/2-12	2	2 3/8	3/4	1 1/2	3/8	1 1/8	3 1/16	3 7/8	8 1/2		
	2	1 1/2-12	1 3/4-12	2 1/4	2 5/8	7/8	1 3/4	3/8	1 1/4	3 3/16	4	8 5/8		
	2 1/2	1 7/8-12	2 1/4-12	3	3 1/8	1	2 1/8	1/2	1 1/2	3 7/16	4 7/16	8 7/8		
	3	2 1/4-12	2 3/4-12	3 1/2	3 3/4	1	2 5/8	1/2	1 1/2	3 7/16	5 1/4	8 7/8		
	3 1/2	2 1/2-12	3 1/4-12	3 1/2	4 1/4	1	3	1/2	1 1/2	3 7/16	5 5/8	8 7/8		
	4	3-12	3 3/4-12	4	4 3/4	1	Δ	1/2	1 1/2	3 7/16	6 7/16	8 7/8		
	4 1/2	3 1/4-12	4 1/4-12	4 1/2	5 1/4	1	Δ	1/2	1 1/2	3 7/16	7 1/8	8 7/8		
10	5	3 1/2-12	4 3/4-12	5	5 3/4	1	Δ	1/2	1 1/2	3 7/16	7 5/8	8 7/8	250	
	1 3/4	1 1/4-12	1 1/2-12	2	2 3/8	3/4	1 1/2	3/8	1 1/8	3 1/8	3 7/8	10 3/8		
	2	1 1/2-12	1 3/4-12	2 1/4	2 5/8	7/8	1 3/4	3/8	1 1/4	3 1/4	4	10 1/2		
	2 1/2	1 7/8-12	2 1/4-12	3	3 1/8	1	2 1/8	1/2	1 1/2	3 1/2	4 7/16	10 3/4		
	3	2 1/4-12	2 3/4-12	3 1/2	3 3/4	1	2 5/8	1/2	1 1/2	3 1/2	5 1/4	10 3/4		
	3 1/2	2 1/2-12	3 1/4-12	3 1/2	4 1/4	1	3	1/2	1 1/2	3 1/2	5 5/8	10 3/4		
	4	3-12	3 3/4-12	4	4 3/4	1	Δ	1/2	1 1/2	3 1/2	6 7/16	10 3/4		
	4 1/2	3 1/4-12	4 1/4-12	4 1/2	5 1/4	1	Δ	1/2	1 1/2	3 1/2	7 1/8	10 3/4		
12	5	3 1/2-12	4 3/4-12	5	5 3/4	1	Δ	1/2	1 1/2	3 1/2	7 5/8	10 3/4	250	
	5 1/2	4-12	5 1/4-12	5 1/2	6 1/4	1	Δ	1/2	1 1/2	3 1/2	8 3/8	10 3/4		
	2	1 1/2-12	1 3/4-12	2 1/4	2 5/8	7/8	1 3/4	3/8	1 1/4	3 1/4	4	11 1/8		
	2 1/2	1 7/8-12	2 1/4-12	3	3 1/8	1	2 1/8	1/2	1 1/2	3 1/2	4 7/16	11 3/8		
	3	2 1/4-12	2 3/4-12	3 1/2	3 3/4	1	2 5/8	1/2	1 1/2	3 1/2	5 1/4	11 3/8		
	3 1/2	2 1/2-12	3 1/4-12	3 1/2	4 1/4	1	3	1/2	1 1/2	3 1/2	5 5/8	11 3/8		
	4	3-12	3 3/4-12	4	4 3/4	1	Δ	1/2	1 1/2	3 1/2	6 7/16	11 3/8		
	4 1/2	3 1/4-12	4 1/4-12	4 1/2	5 1/4	1	Δ	1/2	1 1/2	3 1/2	7 1/8	11 3/8		
14	5	3 1/2-12	4 3/4-12	5	5 3/4	1	Δ	1/2	1 1/2	3 1/2	7 5/8	11 3/8	250	
	5 1/2	4-12	5 1/4-12	5 1/2	6 1/4	1	Δ	1/2	1 1/2	3 1/2	8 3/8	11 3/8		
	2 1/2	1 7/8-12	2 1/4-12	3	3 1/8	1	2 1/8	1/2	1 1/2	3 13/16	4 7/16	12 7/8		
	3	2 1/4-12	2 3/4-12	3 1/2	3 3/4	1	2 5/8	1/2	1 1/2	3 13/16	5 1/4	12 7/8		
	3 1/2	2 1/2-12	3 1/4-12	3 1/2	4 1/4	1	3	1/2	1 1/2	3 13/16	5 5/8	12 7/8		
	4	3-12	3 3/4-12	4	4 3/4	1	Δ	1/2	1 1/2	3 13/16	6 7/16	12 7/8		
	4 1/2	3 1/4-12	4 1/4-12	4 1/2	5 1/4	1	Δ	1/2	1 1/2	3 13/16	7 1/8	12 7/8		
	5	3 1/2-12	4 3/4-12	5	5 3/4	1	Δ	1/2	1 1/2	3 13/16	7 5/8	12 7/8		
5 1/2	4-12	5 1/4-12	5 1/2	6 1/4	1	Δ	1/2	1 1/2	3 13/16	8 3/8	12 7/8			

† HEAD END PORTS SHALLOW TAPPED
 Ω FIXED CUSHIONS FURNISHED AT THE HEAD END IN THESE SIZES
 Δ (4) SPANNER HOLES USED INSTEAD OF FLATS ON 4" DIA. AND LARGER RODS
 § THESE CYLINDERS HAVE FULL PLATE RETAINERS. USE "E" DIMENSION INSTEAD OF "RM" - SEE PAGE 42
 ‡ B DIMENSION TOLERANCE -.001/-.003
 ■ EYE DESIGNED TO FIT YATES STD SWIVEL CLEVIS BRACKET - SEE PAGE 76
NOTE: MPU3 MOUNT DOES NOT INCLUDE PIVOT PIN



CAP FIXED CLEVIS MOUNT

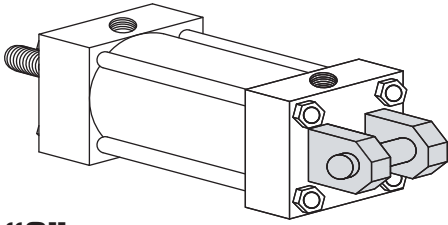

“C”
YATES STYLE C
NFPA-MP1

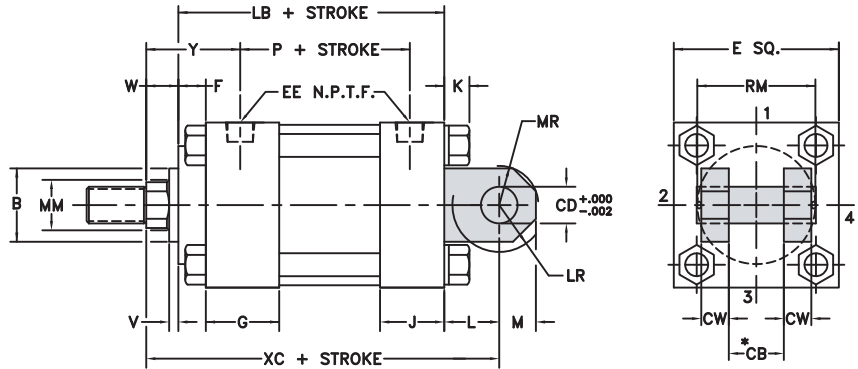

CAP FIXED EYE MOUNT

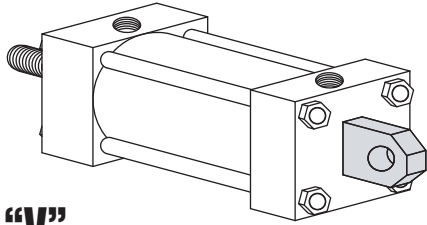

“V”
YATES STYLE V
NFPA-MP3

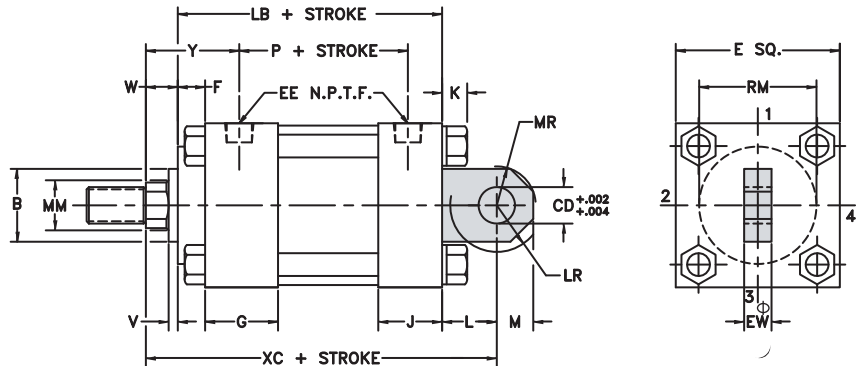

STANDARD ROD ENDS

#2 STD MALE
NFPA-SM

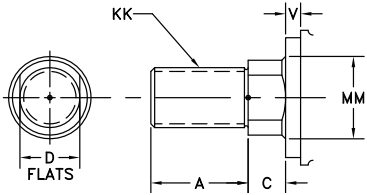

#4 STD FEMALE
NFPA-SF

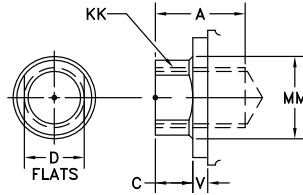

#1 MALE
NFPA-IM

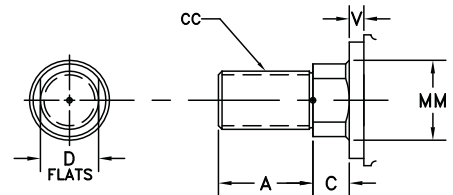

BORE	SAE															ADD STROKE	
	E	EE	OPT	F	G	J	K	CB *	CD	CW	EW ⊕	L	LR	M	MR	LB	P
1 1/2	2	3/8	6	3/8	1 1/2	1	1/4	3/4	1/2	1/2	3/4	3/4	9/16	1/2	9/16	4	2 3/16
2	2 1/2	3/8	6	3/8	1 1/2	1	5/16	3/4	1/2	1/2	3/4	3/4	9/16	1/2	9/16	4	2 3/16
2 1/2	3	3/8	6	3/8	1 1/2	1	5/16	3/4	1/2	1/2	3/4	3/4	9/16	1/2	9/16	4 1/8	2 5/16
3 1/4	3 3/4	1/2	10	5/8	1 3/4	1 1/4	3/8	1 1/4	3/4	5/8	1 1/4	1 1/4	1 1/16	3/4	7/8	4 7/8	2 5/8
4	4 1/2	1/2	10	5/8	1 3/4	1 1/4	3/8	1 1/4	3/4	5/8	1 1/4	1 1/4	1 1/16	3/4	7/8	4 7/8	2 5/8
5	5 1/2	1/2	10	5/8	1 3/4	1 1/4	7/16	1 1/4	3/4	5/8	1 1/4	1 1/4	1 1/16	3/4	7/8	5 1/8	2 7/8
6	6 1/2	3/4	12	3/4	2	1 1/2	7/16	1 1/2	1	3/4	1 1/2	1 1/2	15/16	1	1 1/8	5 3/4	3 1/8
8	8 1/2	3/4	12	3/4	2	1 1/2	9/16	1 1/2	1	3/4	1 1/2	1 1/2	15/16	1	1 1/8	5 7/8	3 1/4

BORE	ROD DIA. MM	ROD EXTENSIONS AND PILOT DIMENSIONS												ADD STROKE	
		KK	CC	A	B ‡	C	D	V	W	Y	RM	XC			
1 1/2	5/8	7/16-20	1/2-20	3/4	1 1/8	3/8	1/2	1/4	5/8	1 31/32	§	5 3/8			
	1†Ω	3/4-16	7/8-14	1 1/8	1 1/2	1/2	7/8	1/2	1	2 11/32	§	5 3/4			
2	5/8	7/16-20	1/2-20	3/4	1 1/8	3/8	1/2	1/4	5/8	1 31/32	§	5 3/8			
	1	3/4-16	7/8-14	1 1/8	1 1/2	1/2	7/8	1/2	1	2 11/32	§	5 3/4			
	1 3/8†Ω	1-14	1 1/4-12	1 5/8	2	5/8	1 1/8	5/8	1 1/4	2 19/32	§	6			
2 1/2	5/8	7/16-20	1/2-20	3/4	1 1/8	3/8	1/2	1/4	5/8	1 31/32	2 3/8	5 1/2			
	1	3/4-16	7/8-14	1 1/8	1 1/2	1/2	7/8	1/2	1	2 11/32	2 1/2	5 7/8			
	1 3/8	1-14	1 1/4-12	1 5/8	2	5/8	1 1/8	5/8	1 1/4	2 19/32	§	6 1/8			
	1 3/4†Ω	1 1/4-12	1 1/2-12	2	2 3/8	3/4	1 1/2	3/4	1 1/2	2 27/32	§	6 3/8			
3 1/4	1	3/4-16	7/8-14	1 1/8	1 1/2	1/2	7/8	1/4	3/4	2 7/16	2 1/2	6 7/8			
	1 3/8	1-14	1 1/4-12	1 5/8	2	5/8	1 1/8	3/8	1	2 11/16	3 7/32	7 1/8			
	1 3/4	1 1/4-12	1 1/2-12	2	2 3/8	3/4	1 1/2	1/2	1 1/4	2 15/16	§	7 3/8			
	2†	1 1/2-12	1 3/4-12	2 1/4	2 5/8	7/8	1 3/4	1/2	1 3/8	3 1/16	§	7 1/2			
	4	3/4-16	7/8-14	1 1/8	1 1/2	1/2	7/8	1/4	3/4	2 7/16	2 1/2	6 7/8			
4	1 3/8	1-14	1 1/4-12	1 5/8	2	5/8	1 1/8	3/8	1	2 11/16	3 7/32	7 1/8			
	1 3/4	1 1/4-12	1 1/2-12	2	2 3/8	3/4	1 1/2	1/2	1 1/4	2 15/16	3 7/8	7 3/8			
	2	1 1/2-12	1 3/4-12	2 1/4	2 5/8	7/8	1 3/4	1/2	1 3/8	3 1/16	4	7 1/2			
	2 1/2†	1 7/8-12	2 1/4-12	3	3 1/8	1	2 1/8	5/8	1 5/8	3 5/16	§	7 3/4			
	5	3/4-16	7/8-14	1 1/8	1 1/2	1/2	7/8	1/4	3/4	2 7/16	2 1/2	7 1/8			
	1 3/8	1-14	1 1/4-12	1 5/8	2	5/8	1 1/8	3/8	1	2 11/16	3 7/32	7 3/8			
5	1 3/4	1 1/4-12	1 1/2-12	2	2 3/8	3/4	1 1/2	1/2	1 1/4	2 15/16	3 7/8	7 5/8			
	2	1 1/2-12	1 3/4-12	2 1/4	2 5/8	7/8	1 3/4	1/2	1 3/8	3 1/16	4	7 3/4			
	2 1/2	1 7/8-12	2 1/4-12	3	3 1/8	1	2 1/8	5/8	1 5/8	3 5/16	4 7/16	8			
	3	2 1/4-12	2 3/4-12	3 1/2	3 3/4	1	2 5/8	5/8	1 5/8	3 5/16	§	8			
	3 1/2†	2 1/2-12	3 1/4-12	3 1/2	4 1/4	1	3	5/8	1 5/8	3 5/16	§	8			
	6	3/4-16	7/8-14	1 1/8	1 1/2	1/2	7/8	1/4	3/4	2 7/16	2 1/2	6 7/8			
	1 3/8	1-14	1 1/4-12	1 5/8	2	5/8	1 1/8	3/8	1	2 11/16	3 7/32	7 3/8			
6	1 3/4	1 1/4-12	1 1/2-12	2	2 3/8	3/4	1 1/2	3/8	1 1/8	3 1/16	3 7/8	8 3/8			
	2	1 1/2-12	1 3/4-12	2 1/4	2 5/8	7/8	1 3/4	3/8	1 1/4	3 3/16	4	8 1/2			
	2 1/2	1 7/8-12	2 1/4-12	3	3 1/8	1	2 1/8	1/2	1 1/2	3 7/16	4 7/16	8 3/4			
	3	2 1/4-12	2 3/4-12	3 1/2	3 3/4	1	2 5/8	1/2	1 1/2	3 7/16	5 1/4	8 3/4			
	3 1/2	2 1/2-12	3 1/4-12	3 1/2	4 1/4	1	3	1/2	1 1/2	3 7/16	5 5/8	8 3/4			
	4	3-12	3 3/4-12	4	4 3/4	1	Δ	1/2	1 1/2	3 7/16	§	8 3/4			
	8	3/4-16	7/8-14	1 1/8	1 1/2	1/2	7/8	1/4	3/4	2 7/16	2 1/2	6 7/8			
	1 3/8	1-14	1 1/4-12	1 5/8	2	5/8	1 1/8	3/8	1	2 11/16	3 7/32	7 3/8			
8	1 3/4	1 1/4-12	1 1/2-12	2	2 3/8	3/4	1 1/2	3/8	1 1/8	3 1/16	3 7/8	8 1/2			
	2	1 1/2-12	1 3/4-12	2 1/4	2 5/8	7/8	1 3/4	3/8	1 1/4	3 3/16	4	8 5/8			
	2 1/2	1 7/8-12	2 1/4-12	3	3 1/8	1	2 1/8	1/2	1 1/2	3 7/16	4 7/16	8 7/8			
	3	2 1/4-12	2 3/4-12	3 1/2	3 3/4	1	2 5/8	1/2	1 1/2	3 7/16	5 1/4	8 7/8			
	3 1/2	2 1/2-12	3 1/4-12	3 1/2	4 1/4	1	3	1/2	1 1/2	3 7/16	5 5/8	8 7/8			
	4	3-12	3 3/4-12	4	4 3/4	1	Δ	1/2	1 1/2	3 7/16	6 7/16	8 7/8			
	4 1/2	3 1/4-12	4 1/4-12	4 1/2	5 1/4	1	Δ	1/2	1 1/2	3 7/16	7 1/8	8 7/8			
	5	3 1/2-12	4 3/4-12	5	5 3/4	1	Δ	1/2	1 1/2	3 7/16	7 5/8	8 7/8			

† HEAD END PORTS SHALLOW TAPPED
Ω FIXED CUSHIONS FURNISHED AT THE HEAD END IN THESE SIZES
Δ (4) SPANNER HOLES USED INSTEAD OF FLATS ON 4" DIA. AND LARGER RODS
§ THESE CYLINDERS HAVE FULL PLATE RETAINERS. USE "E" DIMENSION INSTEAD OF "RM" - SEE PAGE 42
‡ B DIMENSION TOLERANCE -.001/-.003
* CLEVIS DESIGNED TO FIT YATES STD EYE BRACKET - SEE PAGE 75
⊕ EYE DESIGNED TO FIT YATES STD CLEVIS BRACKET - SEE PAGE 74
NOTE: MP3 MOUNT DOES NOT INCLUDE PIVOT PIN



1 1/2 THRU 8 BORE • SERIES A4/L4/H4

BIG BORE CYLINDERS ON NEXT PAGE

CAP FIXED CLEVIS MOUNT

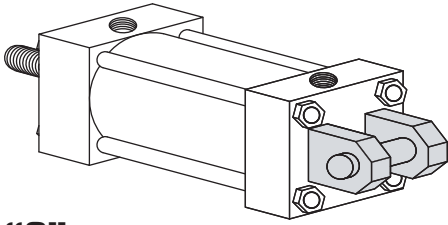

“C”
YATES STYLE C
NFPA-MP1

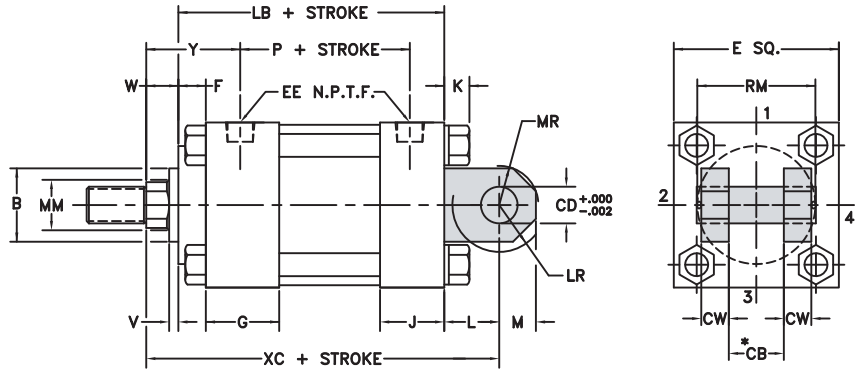

CAP FIXED EYE MOUNT

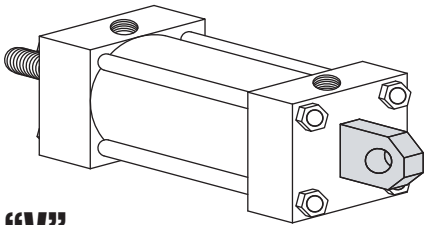

“V”
YATES STYLE V
NFPA-MP3

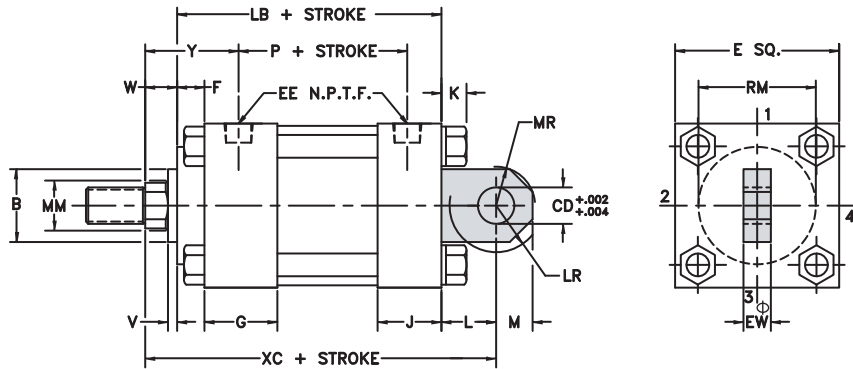

STANDARD ROD ENDS

#2 STD MALE
NFPA-SM

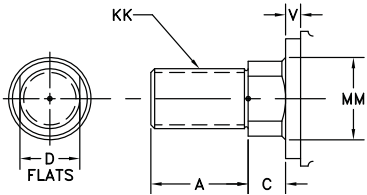

#4 STD FEMALE
NFPA-SF

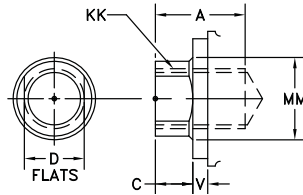

#1 MALE
NFPA-IM

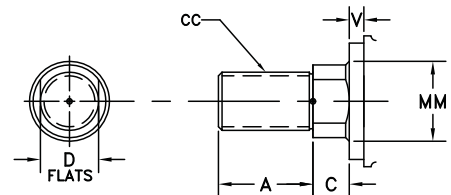

BORE	SAE															ADD STROKE	
	E	EE	OPT	F	G	J	K	CB *	CD	CW	EW Φ	L	LR	M	MR	LB	P
10	10 5/8	1	16	3/4	2 1/4	2	11/16	2	1 3/8	1	2	2 1/8	1 13/16	1 3/8	1 1/2	7 1/8	4 1/8
12	12 3/4	1	16	3/4	2 1/4	2	11/16	2 1/2	1 3/4	1 1/4	2 1/2	2 1/4	1 15/16	1 3/4	1 7/8	7 5/8	4 5/8
14	14 3/4	1 1/4	20	3/4	2 3/4	2 1/4	13/16	2 1/2	2	1 1/4	2 1/2	2 1/2	2 3/16	2	2 3/16	8 7/8	5 1/2
16	17 1/2	1 1/2	24	3/4	2 15/16	2 15/16	15/16	2 1/2	2	1 3/4	2 1/2	3 1/2	3	2 3/4	3	10	6 1/2
18	19 1/2	1 1/2	24	7/8	3 7/16	3 7/16	1	3	2 1/2	2	3	4 1/4	3 3/4	3 1/4	3 1/2	11 1/8	6 1/2
20	21 3/4	2	32	7/8	3 15/16	3 15/16	1 1/8	3	2 1/2	2	3	4 3/4	4 1/4	3 3/4	4 1/16	12 5/8	7 3/8

BORE	ROD DIA. MM	ROD EXTENSIONS AND PILOT DIMENSIONS											ADD STROKE XC
		KK	CC	A	B	C	D	V	W	Y	RM		
10	1 3/4	1 1/4-12	1 1/2-12	2	2 3/8	3/4	1 1/2	3/8	1 1/8	3 1/8	3 7/8	10 3/8	
	2	1 1/2-12	1 3/4-12	2 1/4	2 5/8	7/8	1 3/4	3/8	1 1/4	3 1/4	4	10 1/2	
	2 1/2	1 7/8-12	2 1/4-12	3	3 1/8	1	2 1/8	1/2	1 1/2	3 1/2	4 7/16	10 3/4	
	3	2 1/4-12	2 3/4-12	3 1/2	3 3/4	1	2 5/8	1/2	1 1/2	3 1/2	5 1/4	10 3/4	
	3 1/2	2 1/2-12	3 1/4-12	3 1/2	4 1/4	1	3	1/2	1 1/2	3 1/2	5 5/8	10 3/4	
	4	3-12	3 3/4-12	4	4 3/4	1	Δ	1/2	1 1/2	3 1/2	6 7/16	10 3/4	
	4 1/2	3 1/4-12	4 1/4-12	4 1/2	5 1/4	1	Δ	1/2	1 1/2	3 1/2	7 1/8	10 3/4	
	5	3 1/2-12	4 3/4-12	5	5 3/4	1	Δ	1/2	1 1/2	3 1/2	7 5/8	10 3/4	
5 1/2	4-12	5 1/4-12	5 1/2	6 1/4	1	Δ	1/2	1 1/2	3 1/2	8 3/8	10 3/4		
12	2	1 1/2-12	1 3/4-12	2 1/4	2 5/8	7/8	1 3/4	3/8	1 1/4	3 1/4	4	11 1/8	
	2 1/2	1 7/8-12	2 1/4-12	3	3 1/8	1	2 1/8	1/2	1 1/2	3 1/2	4 7/16	11 3/8	
	3	2 1/4-12	2 3/4-12	3 1/2	3 3/4	1	2 5/8	1/2	1 1/2	3 1/2	5 1/4	11 3/8	
	3 1/2	2 1/2-12	3 1/4-12	3 1/2	4 1/4	1	3	1/2	1 1/2	3 1/2	5 5/8	11 3/8	
	4	3-12	3 3/4-12	4	4 3/4	1	Δ	1/2	1 1/2	3 1/2	6 7/16	11 3/8	
	4 1/2	3 1/4-12	4 1/4-12	4 1/2	5 1/4	1	Δ	1/2	1 1/2	3 1/2	7 1/8	11 3/8	
	5	3 1/2-12	4 3/4-12	5	5 3/4	1	Δ	1/2	1 1/2	3 1/2	7 5/8	11 3/8	
	5 1/2	4-12	5 1/4-12	5 1/2	6 1/4	1	Δ	1/2	1 1/2	3 1/2	8 3/8	11 3/8	
14	2 1/2	1 7/8-12	2 1/4-12	3	3 1/8	1	2 1/8	1/2	1 1/2	3 13/16	4 7/16	12 7/8	
	3	2 1/4-12	2 3/4-12	3 1/2	3 3/4	1	2 5/8	1/2	1 1/2	3 13/16	5 1/4	12 7/8	
	3 1/2	2 1/2-12	3 1/4-12	3 1/2	4 1/4	1	3	1/2	1 1/2	3 13/16	5 5/8	12 7/8	
	4	3-12	3 3/4-12	4	4 3/4	1	Δ	1/2	1 1/2	3 13/16	6 7/16	12 7/8	
	4 1/2	3 1/4-12	4 1/4-12	4 1/2	5 1/4	1	Δ	1/2	1 1/2	3 13/16	7 1/8	12 7/8	
	5	3 1/2-12	4 3/4-12	5	5 3/4	1	Δ	1/2	1 1/2	3 13/16	7 5/8	12 7/8	
	5 1/2	4-12	5 1/4-12	5 1/2	6 1/4	1	Δ	1/2	1 1/2	3 13/16	8 3/8	12 7/8	
	16	3 1/2	2 1/2-12	3 1/4-12	3 1/2	4 1/4	1	3	1/2	1 1/2	3 5/8	5 5/8	15
4	3-12	3 3/4-12	4	4 3/4	1	Δ	1/2	1 1/2	3 5/8	6 7/16	15		
4 1/2	3 1/4-12	4 1/4-12	4 1/2	5 1/4	1	Δ	1/2	1 1/2	3 5/8	7 1/8	15		
5	3 1/2-12	4 3/4-12	5	5 3/4	1	Δ	1/2	1 1/2	3 5/8	7 5/8	15		
5 1/2	4-12	5 1/4-12	5 1/2	6 1/4	1	Δ	1/2	1 1/2	3 5/8	8 3/8	15		
18	4	3-12	3 3/4-12	4	4 3/4	1	Δ	3/8	1 3/8	4 1/8	6 7/16	16 3/4	
	4 1/2	3 1/4-12	4 1/4-12	4 1/2	5 1/4	1	Δ	3/8	1 3/8	4 1/8	7 1/8	16 3/4	
	5	3 1/2-12	4 3/4-12	5	5 3/4	1	Δ	3/8	1 3/8	4 1/8	7 5/8	16 3/4	
	5 1/2	4-12	5 1/4-12	5 1/2	6 1/4	1	Δ	3/8	1 3/8	4 1/8	8 3/8	16 3/4	
20	4	3-12	3 3/4-12	4	4 3/4	1	Δ	3/8	1 3/8	4 7/16	6 7/16	18 3/4	
	4 1/2	3 1/4-12	4 1/4-12	4 1/2	5 1/4	1	Δ	3/8	1 3/8	4 7/16	7 1/8	18 3/4	
	5	3 1/2-12	4 3/4-12	5	5 3/4	1	Δ	3/8	1 3/8	4 7/16	7 5/8	18 3/4	
	5 1/2	4-12	5 1/4-12	5 1/2	6 1/4	1	Δ	3/8	1 3/8	4 7/16	8 3/8	18 3/4	

† HEAD END PORTS SHALLOW TAPPED
 Ω FIXED CUSHIONS FURNISHED AT THE HEAD END IN THESE SIZES
 Δ (4) SPANNER HOLES USED INSTEAD OF FLATS ON 4" DIA. AND LARGER RODS
 § THESE CYLINDERS HAVE FULL PLATE RETAINERS. USE "E" DIMENSION INSTEAD OF "RM" - SEE PAGE 42
 ‡ B DIMENSION TOLERANCE -.001/ -.003
 * CLEVIS DESIGNED TO FIT YATES STD EYE BRACKET - SEE PAGE 75
 Φ EYE DESIGNED TO FIT YATES STD CLEVIS BRACKET - SEE PAGE 74
NOTE: MP3 MOUNT DOES NOT INCLUDE PIVOT PIN



CAP DETACHABLE CLEVIS MOUNT

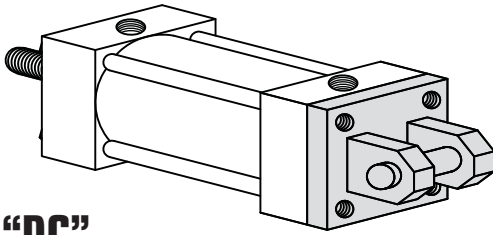

“DC”

YATES STYLE DC
NFPA-MP2

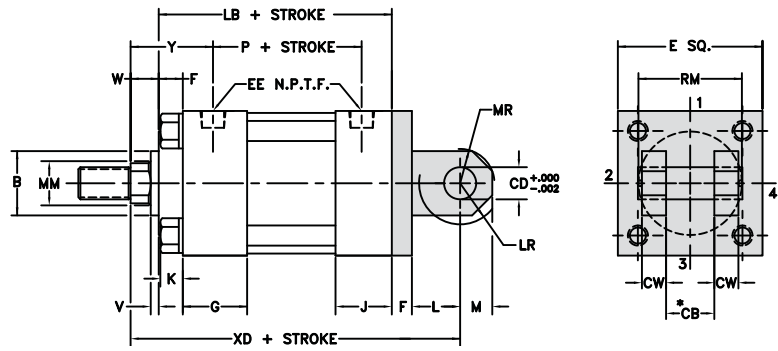

CAP DETACHABLE EYE MOUNT

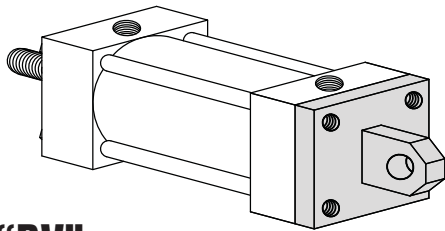

“DV”

YATES STYLE DV
NFPA-MP4

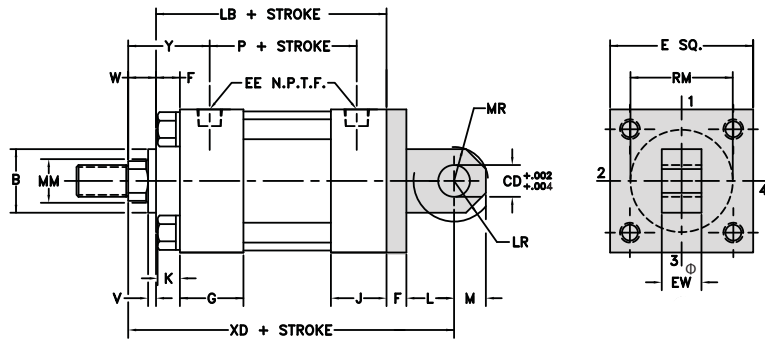

† HEAD END PORTS SHALLOW TAPPED

Ω FIXED CUSHIONS FURNISHED AT THE HEAD END IN THESE SIZES

Δ (4) SPANNER HOLES USED INSTEAD OF FLATS ON 4" DIA. AND LARGER RODS

§ THESE CYLINDERS HAVE FULL PLATE RETAINERS. USE "E" DIMENSION INSTEAD OF "RM" - SEE PAGE 42

‡ B DIMENSION TOLERANCE -.001/ -.003

* CLEVIS DESIGNED TO FIT YATES STD EYE BRACKET - SEE PAGE 75

⊕ EYE DESIGNED TO FIT YATES STD CLEVIS BRACKET - SEE PAGE 74

NOTE: MP4 MOUNT DOES NOT INCLUDE PIVOT PIN

STANDARD ROD ENDS

#2 STD MALE
NFPA-SM

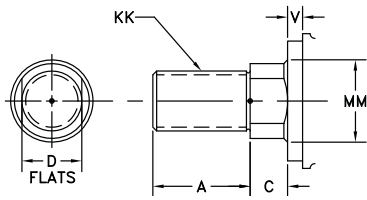

#4 STD FEMALE
NFPA-SF

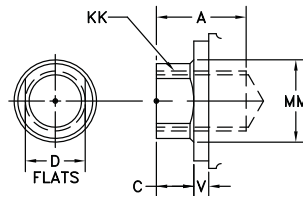

#1 MALE
NFPA-IM

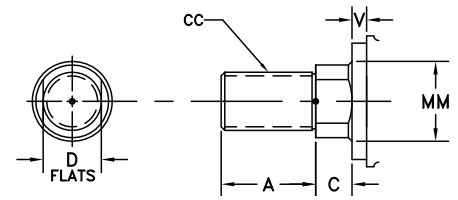

BORE	SAE														ADD STROKE		
	E	EE	OPT	F	G	J	K	CB*	CD	CW	EW Ø	L	LR	M	MR	LB	P
1 1/2	2	3/8	6	3/8	1 1/2	1	1/4	3/4	1/2	1/2	3/4	3/4	9/16	1/2	9/16	4	2 3/16
2	2 1/2	3/8	6	3/8	1 1/2	1	5/16	3/4	1/2	1/2	3/4	3/4	9/16	1/2	9/16	4	2 3/16
2 1/2	3	3/8	6	3/8	1 1/2	1	5/16	3/4	1/2	1/2	3/4	3/4	9/16	1/2	9/16	4 1/8	2 5/16
3 1/4	3 3/4	1/2	10	5/8	1 3/4	1 1/4	3/8	1 1/4	3/4	5/8	1 1/4	1 1/4	1 1/16	3/4	7/8	4 7/8	2 5/8
4	4 1/2	1/2	10	5/8	1 3/4	1 1/4	3/8	1 1/4	3/4	5/8	1 1/4	1 1/4	1 1/16	3/4	7/8	4 7/8	2 5/8
5	5 1/2	1/2	10	5/8	1 3/4	1 1/4	7/16	1 1/4	3/4	5/8	1 1/4	1 1/4	1 1/16	3/4	7/8	5 1/8	2 7/8
6	6 1/2	3/4	12	3/4	2	1 1/2	7/16	1 1/2	1	3/4	1 1/2	1 1/2	1 5/16	1	1 1/8	5 3/4	3 1/8

BORE	ROD DIA.	THREAD		ROD EXTENSIONS AND PILOT DIMENSIONS									ADD STROKE
	MM	KK	CC	A	B±	C	D	V	W	Y	RM	XD	
1 1/2	5/8	7/16-20	1/2-20	3/4	1 1/8	3/8	1/2	1/4	5/8	1 31/32	§	5 3/4	
	1†Ω	3/4-16	7/8-14	1 1/8	1 1/2	1/2	7/8	1/2	1	2 11/32	§	6 1/8	
2	5/8	7/16-20	1/2-20	3/4	1 1/8	3/8	1/2	1/4	5/8	1 31/32	§	5 3/4	
	1	3/4-16	7/8-14	1 1/8	1 1/2	1/2	7/8	1/2	1	2 11/32	§	6 1/8	
2 1/2	1 3/8†Ω	1-14	1 1/4-12	1 5/8	2	5/8	1 1/8	5/8	1 1/4	2 19/32	§	6 3/8	
	5/8	7/16-20	1/2-20	3/4	1 1/8	3/8	1/2	1/4	5/8	1 31/32	2 3/8	5 7/8	
	1	3/4-16	7/8-14	1 1/8	1 1/2	1/2	7/8	1/2	1	2 11/32	2 1/2	6 1/4	
	1 3/8	1-14	1 1/4-12	1 5/8	2	5/8	1 1/8	5/8	1 1/4	2 19/32	§	6 1/2	
3 1/4	1 3/4†Ω	1 1/4-12	1 1/2-12	2	2 3/8	3/4	1 1/2	3/4	1 1/2	2 27/32	§	6 3/4	
	1	3/4-16	7/8-14	1 1/8	1 1/2	1/2	7/8	1/4	3/4	2 7/16	2 1/2	7 1/2	
	1 3/8	1-14	1 1/4-12	1 5/8	2	5/8	1 1/8	3/8	1	2 11/16	3 7/32	7 3/4	
	1 3/4	1 1/4-12	1 1/2-12	2	2 3/8	3/4	1 1/2	1/2	1 1/4	2 15/16	§	8	
4	2†	1 1/2-12	1 3/4-12	2 1/4	2 5/8	7/8	1 3/4	1/2	1 3/8	3 1/16	§	8 1/8	
	1	3/4-16	7/8-14	1 1/8	1 1/2	1/2	7/8	1/4	3/4	2 7/16	2 1/2	7 1/2	
	1 3/8	1-14	1 1/4-12	1 5/8	2	5/8	1 1/8	3/8	1	2 11/16	3 7/32	7 3/4	
	1 3/4	1 1/4-12	1 1/2-12	2	2 3/8	3/4	1 1/2	1/2	1 1/4	2 15/16	3 7/8	8	
	2	1 1/2-12	1 3/4-12	2 1/4	2 5/8	7/8	1 3/4	1/2	1 3/8	3 1/16	4	8 1/8	
5	2 1/2†	1 7/8-12	2 1/4-12	3	3 1/8	1	2 1/8	5/8	1 5/8	3 5/16	§	8 3/8	
	1	3/4-16	7/8-14	1 1/8	1 1/2	1/2	7/8	1/4	3/4	2 7/16	2 1/2	7 3/4	
	1 3/8	1-14	1 1/4-12	1 5/8	2	5/8	1 1/8	3/8	1	2 11/16	3 7/32	8	
	1 3/4	1 1/4-12	1 1/2-12	2	2 3/8	3/4	1 1/2	1/2	1 1/4	2 15/16	3 7/8	8 1/4	
	2	1 1/2-12	1 3/4-12	2 1/4	2 5/8	7/8	1 3/4	1/2	1 3/8	3 1/16	4	8 3/8	
6	2 1/2	1 7/8-12	2 1/4-12	3	3 1/8	1	2 1/8	5/8	1 5/8	3 5/16	4 7/16	8 5/8	
	3	2 1/4-12	2 3/4-12	3 1/2	3 3/4	1	2 5/8	5/8	1 5/8	3 5/16	§	8 5/8	
	3 1/2†	2 1/2-12	3 1/4-12	3 1/2	4 1/4	1	3	5/8	1 5/8	3 5/16	§	8 5/8	
	1 3/8	1-14	1 1/4-12	1 5/8	2	5/8	1 1/8	1/4	7/8	2 13/16	3 7/32	8 7/8	
	1 3/4	1 1/4-12	1 1/2-12	2	2 3/8	3/4	1 1/2	3/8	1 1/8	3 1/16	3 7/8	9 1/8	
6	2	1 1/2-12	1 3/4-12	2 1/4	2 5/8	7/8	1 3/4	3/8	1 1/4	3 3/16	4	9 1/4	
	2 1/2	1 7/8-12	2 1/4-12	3	3 1/8	1	2 1/8	1/2	1 1/2	3 7/16	4 7/16	9 1/2	
	3	2 1/4-12	2 3/4-12	3 1/2	3 3/4	1	2 5/8	1/2	1 1/2	3 7/16	5 1/4	9 1/2	
	3 1/2	2 1/2-12	3 1/4-12	3 1/2	4 1/4	1	3	1/2	1 1/2	3 7/16	5 5/8	9 1/2	
	4	3-12	3 3/4-12	4	4 3/4	1	Δ	1/2	1 1/2	3 7/16	§	9 1/2	



1 1/2 THRU 6 BORE • SERIES A4/L4/H4

INTERMEDIATE FIXED TRUNNION MOUNT

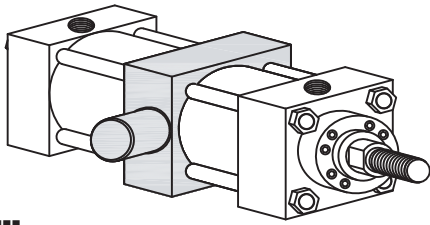

“T”
YATES STYLE **T**
NFPA-MT4

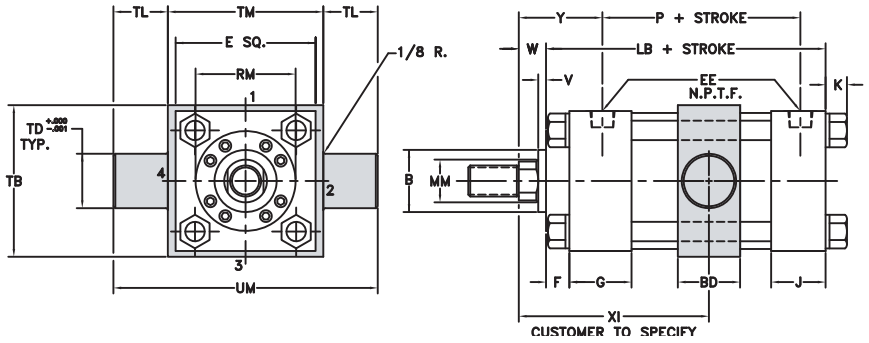

HEAD TRUNNION MOUNT

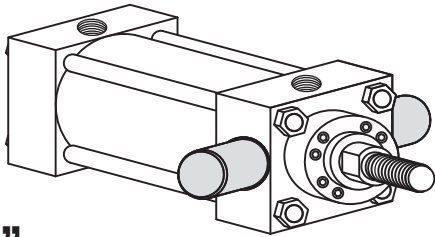

“U”
YATES STYLE **U**
NFPA-MT1

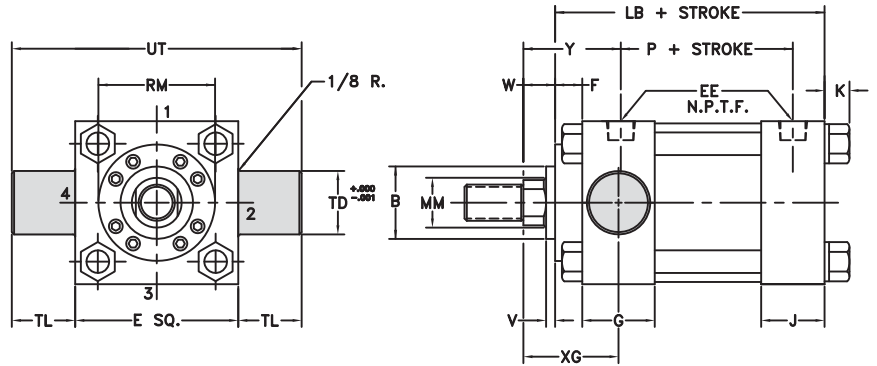

CAP TRUNNION MOUNT

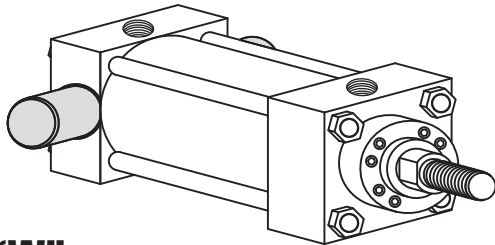

“W”
YATES STYLE **W**
NFPA-MT2

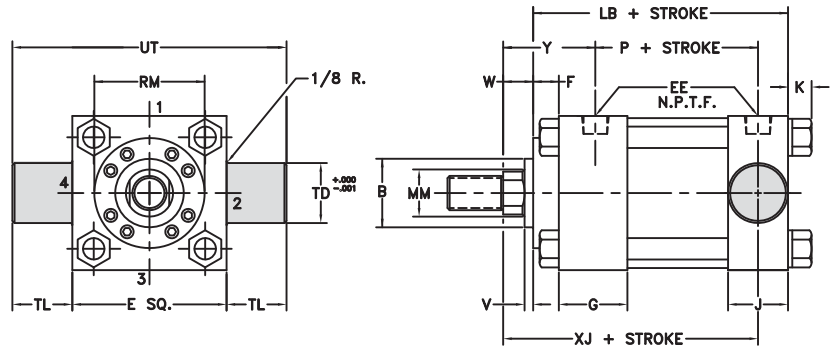

STANDARD ROD ENDS

#2 STD MALE
NFPA-SM

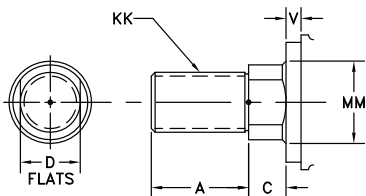

#4 STD FEMALE
NFPA-SF

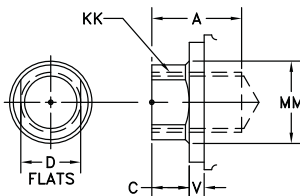

#1 MALE
NFPA-IM

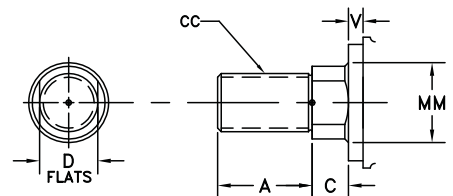

BORE	SAE														XI	ADD STROKE	
	E	EE	OPT	F	G	J	K	TD	TL	UT	TB	TM	UM	BD		LB	P
1 1/2	2	3/8	6	3/8	1 1/2	1	1/4	1	1	4	2 1/2	2 1/2	4 1/2	1 1/4	SPECIFY	4	2 3/16
2	2 1/2	3/8	6	3/8	1 1/2	1	5/16	1	1	4 1/2	3	3	5	1 1/2		4	2 3/16
2 1/2	3	3/8	6	3/8	1 1/2	1	5/16	1	1	5	3 1/2	3 1/2	5 1/2	1 1/2		4 1/8	2 5/16
3 1/4	3 3/4	1/2	10	5/8	1 3/4	1 1/4	3/8	1	1	5 3/4	4 1/4	4 1/2	6 1/2	2		4 7/8	2 5/8
4	4 1/2	1/2	10	5/8	1 3/4	1 1/4	3/8	1	1	6 1/2	5	5 1/4	7 1/4	2		4 7/8	2 5/8
5	5 1/2	1/2	10	5/8	1 3/4	1 1/4	3/8	1	1	7 1/2	6	6 1/4	8 1/4	2		5 1/8	2 7/8
6	6 1/2	3/4	12	3/4	2	1 1/2	7/16	1 3/8	1 3/8	9 1/4	7	7 5/8	10 3/8	2 1/2		5 3/4	3 1/8
8	8 1/2	3/4	12	3/4	2	1 1/2	9/16	1 3/8	1 3/8	11 1/4	9 1/2	9 3/4	12 1/2	2 1/2		5 7/8	3 1/4

BORE	ROD DIA.		THREAD		ROD EXTENSIONS AND PILOT DIMENSIONS								ADD STROKE	
	MM	KK	CC	A	B ‡	C	D	V	W	Y	RM	XG	XJ	
1 1/2	5/8	7/16-20	1/2-20	3/4	1 1/8	3/8	1/2	1/4	5/8	1 31/32	§	1 3/4	4 1/8	
	1†Ω	3/4-16	7/8-14	1 1/8	1 1/2	1/2	7/8	1/2	1	2 11/32	§	2 1/8	4 1/2	
2	5/8	7/16-20	1/2-20	3/4	1 1/8	3/8	1/2	1/4	5/8	1 31/32	§	1 3/4	4 1/8	
	1	3/4-16	7/8-14	1 1/8	1 1/2	1/2	7/8	1/2	1	2 11/32	§	2 1/8	4 1/2	
2 1/2	5/8	7/16-20	1/2-20	3/4	1 1/8	3/8	1/2	1/4	5/8	1 31/32	2 3/8	1 3/4	4 1/4	
	1	3/4-16	7/8-14	1 1/8	1 1/2	1/2	7/8	1/2	1	2 11/32	2 1/2	2 1/8	4 5/8	
3 1/4	1	3/4-16	7/8-14	1 1/8	1 1/2	1/2	7/8	1/4	3/4	2 7/16	2 1/2	2 1/4	5	
	1 3/8	1-14	1 1/4-12	1 5/8	2	5/8	1 1/8	5/8	1 1/4	2 19/32	§	2 3/8	4 7/8	
4	1 3/8	1 1/4-12	1 1/2-12	2	2 3/8	3/4	1 1/2	3/4	1 1/2	2 27/32	§	2 5/8	5 1/8	
	1	3/4-16	7/8-14	1 1/8	1 1/2	1/2	7/8	1/4	3/4	2 7/16	2 1/2	2 1/4	5	
5	1 3/8	1-14	1 1/4-12	1 5/8	2	5/8	1 1/8	3/8	1	2 11/16	3 7/32	2 1/2	5 1/2	
	1 3/4	1 1/4-12	1 1/2-12	2	2 3/8	3/4	1 1/2	1/2	1 1/4	2 15/16	3 7/8	2 3/4	5 3/4	
6	2	1 1/2-12	1 3/4-12	2 1/4	2 5/8	7/8	1 3/4	1/2	1 3/8	3 1/16	4	2 7/8	5 7/8	
	2 1/2	1 7/8-12	2 1/4-12	3	3 1/8	1	2 1/8	5/8	1 5/8	3 5/16	§	3 1/8	6 1/8	
8	1 3/8	1-14	1 1/4-12	1 5/8	2	5/8	1 1/8	1/4	7/8	2 13/16	3 7/32	2 5/8	5 7/8	
	1 3/4	1 1/4-12	1 1/2-12	2	2 3/8	3/4	1 1/2	3/8	1 1/8	3 1/16	3 7/8	2 7/8	6 1/8	
2	1 1/2-12	1 3/4-12	2 1/4-12	2 1/4	2 5/8	7/8	1 3/4	3/8	1 1/4	3 3/16	4	3	6 1/4	
	2 1/2	1 7/8-12	2 1/4-12	3	3 1/8	1	2 1/8	1/2	1 1/2	3 7/16	4 7/16	3 1/4	6 1/2	
3	2 1/4-12	2 3/4-12	3 1/2-12	3 1/2	3 3/4	1	2 5/8	1/2	1 1/2	3 7/16	5 1/4	3 1/4	6 1/2	
	3 1/2	2 1/2-12	3 1/4-12	3 1/2	4 1/4	1	3	1/2	1 1/2	3 7/16	5 5/8	3 1/4	6 1/2	
4	3-12	3 3/4-12	4-12	4	4 3/4	1	Δ	1/2	1 1/2	3 7/16	§	3 1/4	6 1/2	
	1 3/8	1-14	1 1/4-12	1 5/8	2	5/8	1 1/8	1/4	7/8	2 13/16	3 7/32	2 5/8	6	
1 3/4	1 1/4-12	1 1/2-12	2 1/4-12	2	2 3/8	3/4	1 1/2	3/8	1 1/8	3 1/16	3 7/8	2 7/8	6 1/4	
	2	1 1/2-12	1 3/4-12	2 1/4	2 5/8	7/8	1 3/4	3/8	1 1/4	3 3/16	4	3	6 3/8	
2 1/2	1 7/8-12	2 1/4-12	3 1/2-12	3	3 1/8	1	2 1/8	1/2	1 1/2	3 7/16	4 7/16	3 1/4	6 5/8	
	3	2 1/4-12	2 3/4-12	3 1/2	3 3/4	1	2 5/8	1/2	1 1/2	3 7/16	5 1/4	3 1/4	6 5/8	
3 1/2	2 1/2-12	3 1/4-12	3 1/2-12	3 1/2	4 1/4	1	3	1/2	1 1/2	3 7/16	5 5/8	3 1/4	6 5/8	
	4	3-12	3 3/4-12	4	4 3/4	1	Δ	1/2	1 1/2	3 7/16	6 7/16	3 1/4	6 5/8	
4 1/2	3-12	3 3/4-12	4 1/2-12	4 1/2	5 1/4	1	Δ	1/2	1 1/2	3 7/16	7 1/8	3 1/4	6 5/8	
	5	3 1/2-12	4 3/4-12	5	5 3/4	1	Δ	1/2	1 1/2	3 7/16	7 5/8	3 1/4	6 5/8	

† HEAD END PORTS SHALLOW TAPPED
Ω FIXED CUSHIONS FURNISHED AT THE HEAD END IN THESE SIZES
Δ (4) SPANNER HOLES USED INSTEAD OF FLATS ON 4" DIA. AND LARGER RODS
§ THESE CYLINDERS HAVE FULL PLATE RETAINERS. USE "E" DIMENSION INSTEAD OF "RM" -- SEE PAGE 42
‡ B DIMENSION TOLERANCE -.001/-.003



INTERMEDIATE FIXED TRUNNION MOUNT

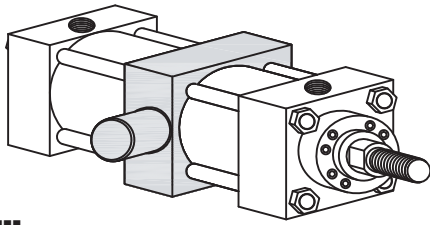

“T”
YATES STYLE T
NFPA-MT4

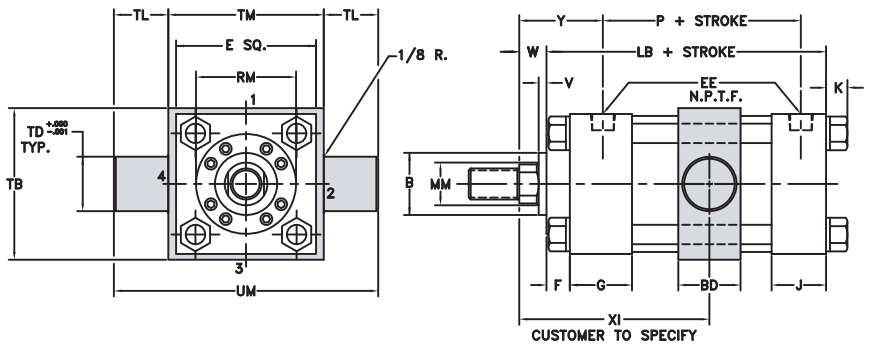

HEAD TRUNNION MOUNT

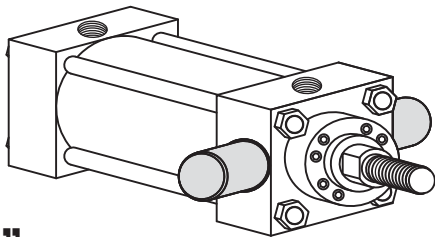

“U”
YATES STYLE U
NFPA-MT1

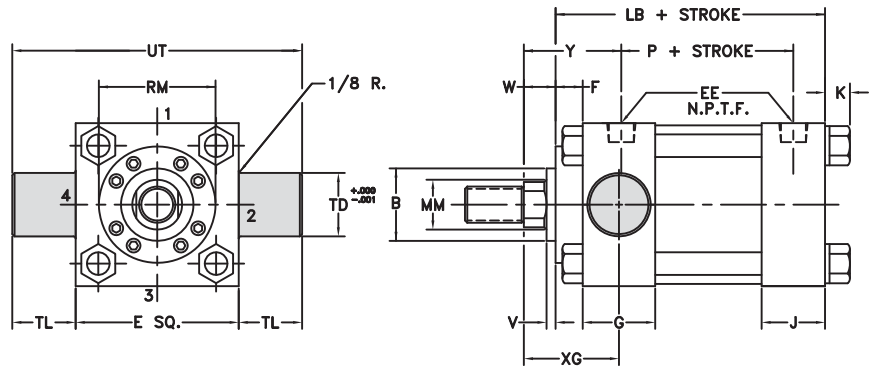

CAP TRUNNION MOUNT

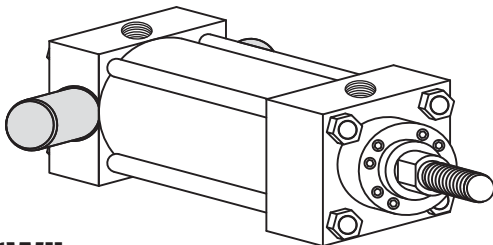

“W”
YATES STYLE W
NFPA-MT2

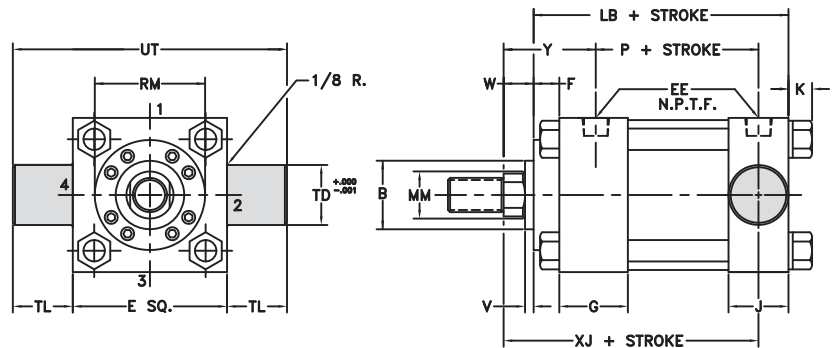

STANDARD ROD ENDS

#2 STD MALE
NFPA-SM

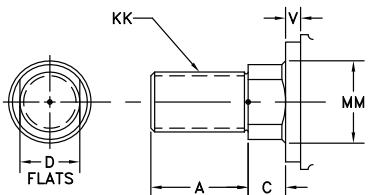

#4 STD FEMALE
NFPA-SF

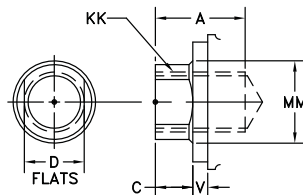

#1 MALE
NFPA-IM

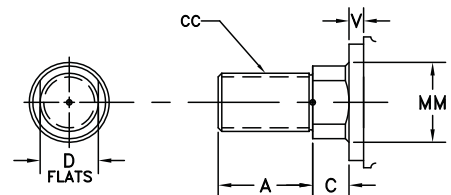

BORE	SAE														XI	ADD STROKE		
	E	EE	OPT	F	G	J	K	TD	TL	UT	TB	TM	UM	BD		LB	P	
10	10 5/8	1	16	3/4	2 1/4	2	11/16	1 3/4	1 3/4	14 1/8	11 3/4	12	15 1/2	3	SPECIFY	7 1/8	4 1/8	
12	12 3/4	1	16	3/4	2 1/4	2	11/16	1 3/4	1 3/4	16 1/4	13 3/4	14	17 1/2	3		7 5/8	4 5/8	
14	14 3/4	1 1/4	20	3/4	2 3/4	2 1/4	13/16	2	2	18 3/4	16	16 1/4	20 1/4	3 1/2		8 7/8	5 1/2	
16	17 1/2	1 1/2	24	3/4	2 15/16	2 15/16	15/16	2 3/4	2 3/4	23	NA	NA	NA	NA		NA	10	6 1/2
18	19 1/2	1 1/2	24	7/8	3 7/16	3 7/16	1	3	3	25 1/2	NA	NA	NA	NA		NA	11 1/8	6 1/2
20	21 3/4	2	32	7/8	3 15/16	3 15/16	1 1/8	3 1/2	3 1/2	28 3/4	NA	NA	NA	NA	NA	12 5/8	7 3/8	

BORE	ROD DIA.	THREAD		ROD EXTENSIONS AND PILOT DIMENSIONS									ADD STROKE
	MM	KK	CC	A	B ‡	C	D	V	W	Y	RM	XG	XJ
10	1 3/4	1 1/4-12	1 1/2-12	2	2 3/8	3/4	1 1/2	3/8	1 1/8	3 1/8	3 7/8	3	7 1/4
	2	1 1/2-12	1 3/4-12	2 1/4	2 5/8	7/8	1 3/4	3/8	1 1/4	3 1/4	4	3 1/8	7 3/8
	2 1/2	1 7/8-12	2 1/4-12	3	3 1/8	1	2 1/8	1/2	1 1/2	3 1/2	4 7/16	3 3/8	7 5/8
	3	2 1/4-12	2 3/4-12	3 1/2	3 3/4	1	2 5/8	1/2	1 1/2	3 1/2	5 1/4	3 3/8	7 5/8
	3 1/2	2 1/2-12	3 1/4-12	3 1/2	4 1/4	1	3	1/2	1 1/2	3 1/2	5 5/8	3 3/8	7 5/8
	4	3-12	3 3/4-12	4	4 3/4	1	Δ	1/2	1 1/2	3 1/2	6 7/16	3 3/8	7 5/8
	4 1/2	3 1/4-12	4 1/4-12	4 1/2	5 1/4	1	Δ	1/2	1 1/2	3 1/2	7 1/8	3 3/8	7 5/8
	5	3 1/2-12	4 3/4-12	5	5 3/4	1	Δ	1/2	1 1/2	3 1/2	7 5/8	3 3/8	7 5/8
12	5 1/2	4-12	5 1/4-12	5 1/2	6 1/4	1	Δ	1/2	1 1/2	3 1/2	8 3/8	3 3/8	7 5/8
	2	1 1/2-12	1 3/4-12	2 1/4	2 5/8	7/8	1 3/4	3/8	1 1/4	3 1/4	4	3 1/8	7 7/8
	2 1/2	1 7/8-12	2 1/4-12	3	3 1/8	1	2 1/8	1/2	1 1/2	3 1/2	4 7/16	3 3/8	8 1/8
	3	2 1/4-12	2 3/4-12	3 1/2	3 3/4	1	2 5/8	1/2	1 1/2	3 1/2	5 1/4	3 3/8	8 1/8
	3 1/2	2 1/2-12	3 1/4-12	3 1/2	4 1/4	1	3	1/2	1 1/2	3 1/2	5 5/8	3 3/8	8 1/8
	4	3-12	3 3/4-12	4	4 3/4	1	Δ	1/2	1 1/2	3 1/2	6 7/16	3 3/8	8 1/8
	4 1/2	3 1/4-12	4 1/4-12	4 1/2	5 1/4	1	Δ	1/2	1 1/2	3 1/2	7 1/8	3 3/8	8 1/8
	5	3 1/2-12	4 3/4-12	5	5 3/4	1	Δ	1/2	1 1/2	3 1/2	7 5/8	3 3/8	8 1/8
14	5 1/2	4-12	5 1/4-12	5 1/2	6 1/4	1	Δ	1/2	1 1/2	3 1/2	8 3/8	3 3/8	8 1/8
	2 1/2	1 7/8-12	2 1/4-12	3	3 1/8	1	2 1/8	1/2	1 1/2	3 13/16	4 7/16	3 5/8	9 1/4
	3	2 1/4-12	2 3/4-12	3 1/2	3 3/4	1	2 5/8	1/2	1 1/2	3 13/16	5 1/4	3 5/8	9 1/4
	3 1/2	2 1/2-12	3 1/4-12	3 1/2	4 1/4	1	3	1/2	1 1/2	3 13/16	5 5/8	3 5/8	9 1/4
	4	3-12	3 3/4-12	4	4 3/4	1	Δ	1/2	1 1/2	3 13/16	6 7/16	3 5/8	9 1/4
	4 1/2	3 1/4-12	4 1/4-12	4 1/2	5 1/4	1	Δ	1/2	1 1/2	3 13/16	7 1/8	3 5/8	9 1/4
	5	3 1/2-12	4 3/4-12	5	5 3/4	1	Δ	1/2	1 1/2	3 13/16	7 5/8	3 5/8	9 1/4
	5 1/2	4-12	5 1/4-12	5 1/2	6 1/4	1	Δ	1/2	1 1/2	3 13/16	8 3/8	3 5/8	9 1/4
16	3 1/2	2 1/2-12	3 1/4-12	3 1/2	4 1/4	1	3	1/2	1 1/2	3 5/8	5 5/8	3 11/16	10 1/16
	4	3-12	3 3/4-12	4	4 3/4	1	Δ	1/2	1 1/2	3 5/8	6 7/16	3 11/16	10 1/16
	4 1/2	3 1/4-12	4 1/4-12	4 1/2	5 1/4	1	Δ	1/2	1 1/2	3 5/8	7 1/8	3 11/16	10 1/16
	5	3 1/2-12	4 3/4-12	5	5 3/4	1	Δ	1/2	1 1/2	3 5/8	7 5/8	3 11/16	10 1/16
	5 1/2	4-12	5 1/4-12	5 1/2	6 1/4	1	Δ	1/2	1 1/2	3 5/8	8 3/8	3 11/16	10 1/16
18	4	3-12	3 3/4-12	4	4 3/4	1	Δ	3/8	1 3/8	4 1/8	6 7/16	3 15/16	10 13/16
	4 1/2	3 1/4-12	4 1/4-12	4 1/2	5 1/4	1	Δ	3/8	1 3/8	4 1/8	7 1/8	3 15/16	10 13/16
	5	3 1/2-12	4 3/4-12	5	5 3/4	1	Δ	3/8	1 3/8	4 1/8	7 5/8	3 15/16	10 13/16
	5 1/2	4-12	5 1/4-12	5 1/2	6 1/4	1	Δ	3/8	1 3/8	4 1/8	8 3/8	3 15/16	10 13/16
20	4	3-12	3 3/4-12	4	4 3/4	1	Δ	3/8	1 3/8	4 7/16	6 7/16	4 3/16	12 1/16
	4 1/2	3 1/4-12	4 1/4-12	4 1/2	5 1/4	1	Δ	3/8	1 3/8	4 7/16	7 1/8	4 3/16	12 1/16
	5	3 1/2-12	4 3/4-12	5	5 3/4	1	Δ	3/8	1 3/8	4 7/16	7 5/8	4 3/16	12 1/16
	5 1/2	4-12	5 1/4-12	5 1/2	6 1/4	1	Δ	3/8	1 3/8	4 7/16	8 3/8	4 3/16	12 1/16

† HEAD END PORTS SHALLOW TAPPED
Ω FIXED CUSHIONS FURNISHED AT THE HEAD END IN THESE SIZES
Δ (4) SPANNER HOLES USED INSTEAD OF FLATS ON 4" DIA. AND LARGER RODS
§ THESE CYLINDERS HAVE FULL PLATE RETAINERS. USE "E" DIMENSION INSTEAD OF "RM" - SEE PAGE 42
‡ B DIMENSION TOLERANCE -.001/-.003



HEAD RECTANGULAR FLANGE MOUNT

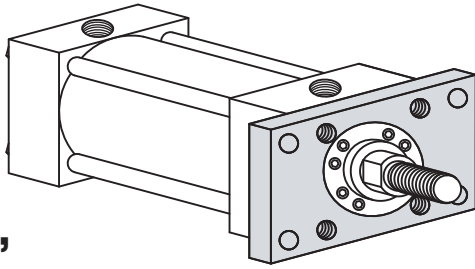

“F”

YATES STYLE **F**
NFPA-MF1

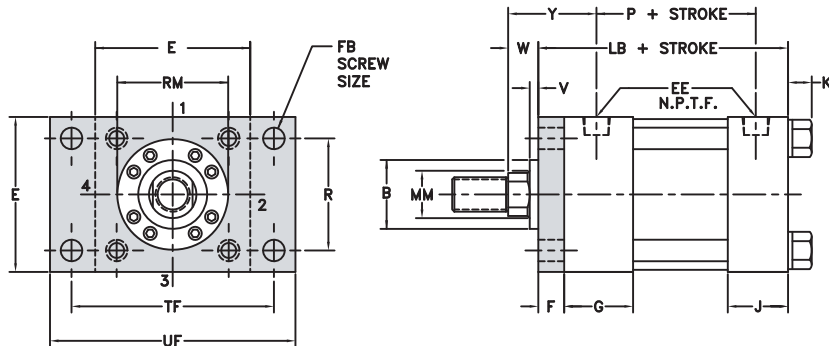

HEAD SQUARE FLANGE MOUNT

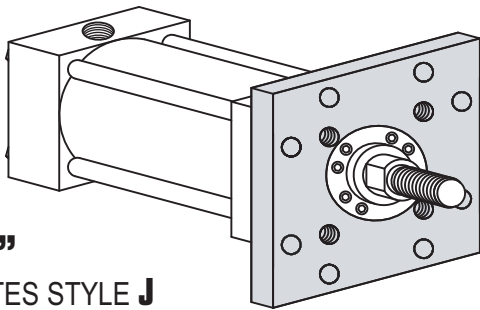

“J”

YATES STYLE **J**
NFPA-MF5

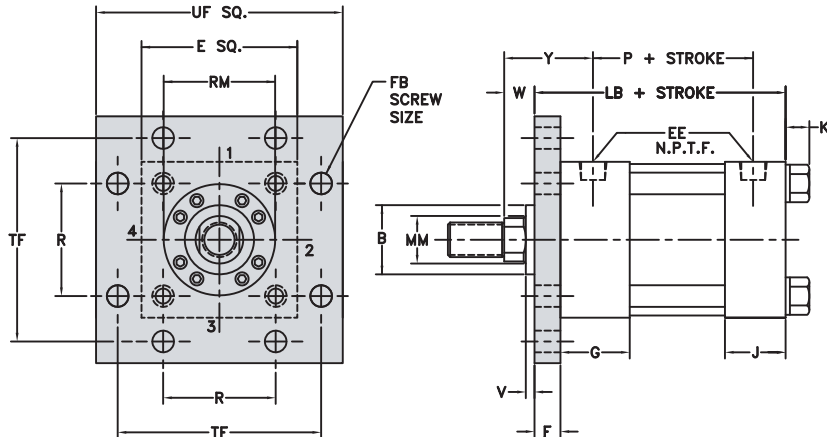

CAP RECTANGULAR FLANGE MOUNT

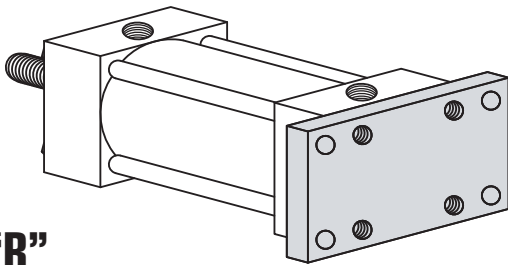

“R”

YATES STYLE **R**
NFPA-MF2

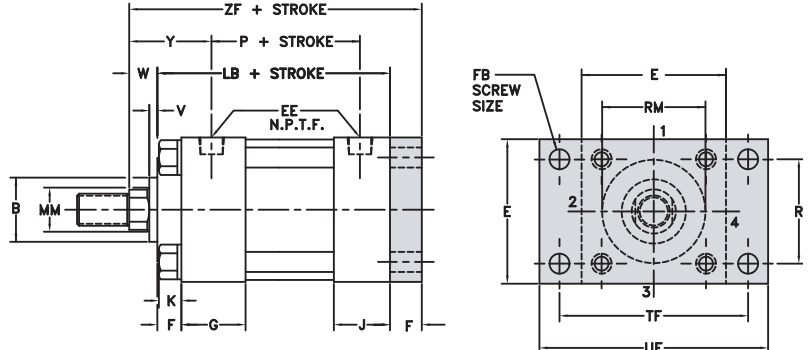

CAP SQUARE FLANGE MOUNT

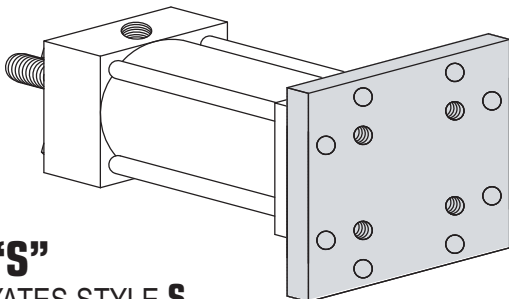

“S”

YATES STYLE **S**
NFPA-MF6

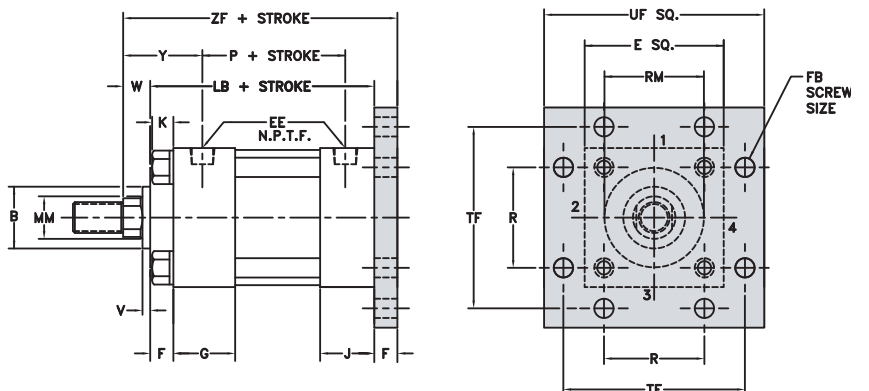

STANDARD ROD ENDS

#2 STD MALE NFPA-SM

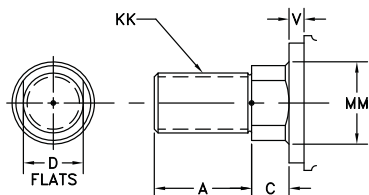

#4 STD FEMALE NFPA-SF

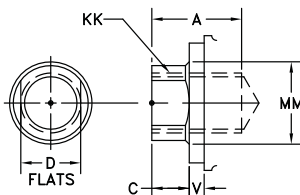

#1 MALE NFPA-IM

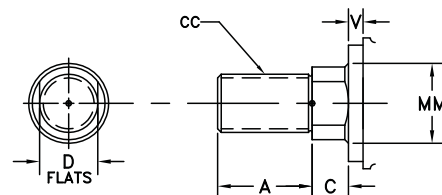

BORE	SAE											ADD STROKE	
	E	EE	OPT	F	G	J	K	FB	R	TF	UF	LB	P
1 1/2	2	3/8	6	3/8	1 1/2	1	1/4	1/4	1.43	2 3/4	3 3/8	4	2 3/16
2	2 1/2	3/8	6	3/8	1 1/2	1	5/16	5/16	1.84	3 3/8	4 1/8	4	2 3/16
2 1/2	3	3/8	6	3/8	1 1/2	1	5/16	5/16	2.19	3 7/8	4 5/8	4 1/8	2 5/16
3 1/4	3 3/4	1/2	10	5/8	1 3/4	1 1/4	3/8	3/8	2.76	4 11/16	5 1/2	4 7/8	2 5/8
4	4 1/2	1/2	10	5/8	1 3/4	1 1/4	3/8	3/8	3.32	5 7/16	6 1/4	4 7/8	2 5/8
5	5 1/2	1/2	10	5/8	1 3/4	1 1/4	7/16	1/2	4.10	6 5/8	7 5/8	5 1/8	2 7/8
6	6 1/2	3/4	12	3/4	2	1 1/2	7/16	1/2	4.88	7 5/8	8 5/8	5 3/4	3 1/8

BORE	ROD DIA. MM	THREAD		ROD EXTENSIONS AND PILOT DIMENSIONS								ADD STROKE	F MOUNT MAX PSI
		KK	CC	A	B±	C	D	V	W	Y	RM	ZF	PUSH
1 1/2	5/8	7/16-20	1/2-20	3/4	1 1/8	3/8	1/2	1/4	5/8	1 31/32	§	5	650
	1†Ω	3/4-16	7/8-14	1 1/8	1 1/2	1/2	7/8	1/2	1	2 11/32	§	5 3/8	375
2	5/8	7/16-20	1/2-20	3/4	1 1/8	3/8	1/2	1/4	5/8	1 31/32	§	5	500
	1	3/4-16	7/8-14	1 1/8	1 1/2	1/2	7/8	1/2	1	2 11/32	§	5 3/8	350
2 1/2	1 3/8†Ω	1-14	1 1/4-12	1 5/8	2	5/8	1 1/8	5/8	1 1/4	2 19/32	§	5 5/8	200
	5/8	7/16-20	1/2-20	3/4	1 1/8	3/8	1/2	1/4	5/8	1 31/32	2 3/8	5 1/8	300
2 1/2	1	3/4-16	7/8-14	1 1/8	1 1/2	1/2	7/8	1/2	1	2 11/32	2 1/2	5 1/2	300
	1 3/8	1-14	1 1/4-12	1 5/8	2	5/8	1 1/8	5/8	1 1/4	2 19/32	§	5 3/4	200
3 1/4	1 3/4†Ω	1 1/4-12	1 1/2-12	2	2 3/8	3/4	1 1/2	3/4	1 1/2	2 27/32	§	6	150
	1	3/4-16	7/8-14	1 1/8	1 1/2	1/2	7/8	1/4	3/4	2 7/16	2 1/2	6 1/4	650
3 1/4	1 3/8	1-14	1 1/4-12	1 5/8	2	5/8	1 1/8	3/8	1	2 11/16	3 7/32	6 1/2	650
	1 3/4	1 1/4-12	1 1/2-12	2	2 3/8	3/4	1 1/2	1/2	1 1/4	2 15/16	§	6 3/4	400
4	2†	1 1/2-12	1 3/4-12	2 1/4	2 5/8	7/8	1 3/4	1/2	1 3/8	3 1/16	§	6 7/8	350
	1	3/4-16	7/8-14	1 1/8	1 1/2	1/2	7/8	1/4	3/4	2 7/16	2 1/2	6 1/4	450
4	1 3/8	1-14	1 1/4-12	1 5/8	2	5/8	1 1/8	3/8	1	2 11/16	3 7/32	6 1/2	450
	1 3/4	1 1/4-12	1 1/2-12	2	2 3/8	3/4	1 1/2	1/2	1 1/4	2 15/16	3 7/8	6 3/4	325
5	2	1 1/2-12	1 3/4-12	2 1/4	2 5/8	7/8	1 3/4	1/2	1 3/8	3 1/16	4	6 7/8	325
	2 1/2†	1 7/8-12	2 1/4-12	3	3 1/8	1	2 1/8	5/8	1 5/8	3 5/16	§	7 1/8	225
5	1	3/4-16	7/8-14	1 1/8	1 1/2	1/2	7/8	1/4	3/4	2 7/16	2 1/2	6 1/2	300
	1 3/8	1-14	1 1/4-12	1 5/8	2	5/8	1 1/8	3/8	1	2 11/16	3 7/32	6 3/4	300
6	1 3/4	1 1/4-12	1 1/2-12	2	2 3/8	3/4	1 1/2	1/2	1 1/4	2 15/16	3 7/8	7	300
	2	1 1/2-12	1 3/4-12	2 1/4	2 5/8	7/8	1 3/4	1/2	1 3/8	3 1/16	4	7 1/8	225
6	2 1/2	1 7/8-12	2 1/4-12	3	3 1/8	1	2 1/8	5/8	1 5/8	3 5/16	4 7/16	7 3/8	225
	3	2 1/4-12	2 3/4-12	3 1/2	3 3/4	1	2 5/8	5/8	1 5/8	3 5/16	§	7 3/8	175
6	3 1/2†	2 1/2-12	3 1/4-12	3 1/2	4 1/4	1	3	5/8	1 5/8	3 5/16	§	7 3/8	125
	1 3/8	1-14	1 1/4-12	1 5/8	2	5/8	1 1/8	1/4	7/8	2 13/16	3 7/32	7 3/8	350
6	1 3/4	1 1/4-12	1 1/2-12	2	2 3/8	3/4	1 1/2	3/8	1 1/8	3 1/16	3 7/8	7 5/8	350
	2	1 1/2-12	1 3/4-12	2 1/4	2 5/8	7/8	1 3/4	3/8	1 1/4	3 3/16	4	7 3/4	300
6	2 1/2	1 7/8-12	2 1/4-12	3	3 1/8	1	2 1/8	1/2	1 1/2	3 7/16	4 7/16	8	300
	3	2 1/4-12	2 3/4-12	3 1/2	3 3/4	1	2 5/8	1/2	1 1/2	3 7/16	5 1/4	8	200
6	3 1/2	2 1/2-12	3 1/4-12	3 1/2	4 1/4	1	3	1/2	1 1/2	3 7/16	5 5/8	8	200
	4	3-12	3 3/4-12	4	4 3/4	1	Δ	1/2	1 1/2	3 7/16	§	8	200

† HEAD END PORTS SHALLOW TAPPED
 Ω FIXED CUSHIONS FURNISHED AT THE HEAD END IN THESE SIZES
 Δ (4) SPANNER HOLES USED INSTEAD OF FLATS ON 4" DIA. AND LARGER RODS
 § THESE CYLINDERS HAVE FULL PLATE RETAINERS. USE "E" DIMENSION INSTEAD OF "RM" - SEE PAGE 42
 ‡ B DIMENSION TOLERANCE -.001/- .003



HEAD RECTANGULAR INTEGRAL FLANGE MOUNT

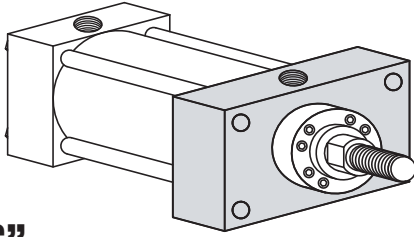

“G”
YATES STYLE **G**
NFPA-ME5

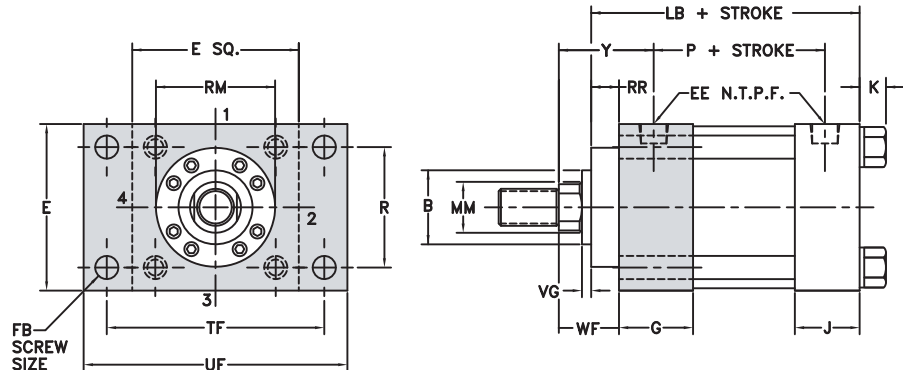

CAP RECTANGULAR INTEGRAL FLANGE MOUNT

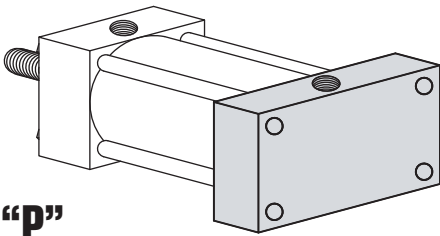

“P”
YATES STYLE **P**
NFPA-ME6

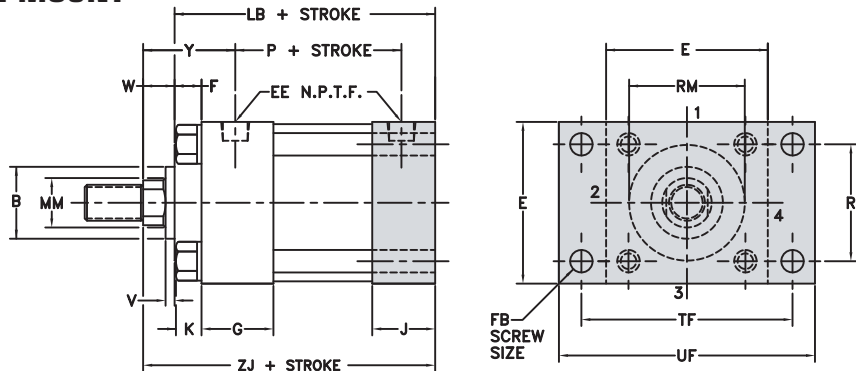

STANDARD ROD ENDS

#2 STD MALE
NFPA-SM

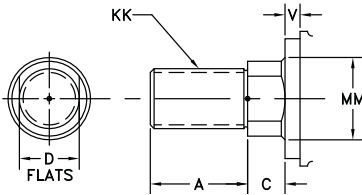

#4 STD FEMALE
NFPA-SF

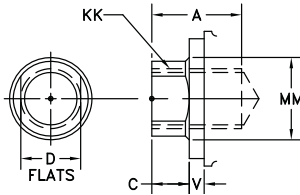

#1 MALE
NFPA-IM

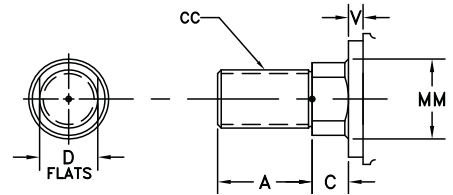

BORE	SAE											ADD STROKE	
	E	EE	OPT	F	G	J	K	FB	R	TF	UF	LB	P
1 1/2	2	3/8	6	3/8	1 1/2	1	1/4	1/4	1.43	2 3/4	3 3/8	4	2 3/16
2	2 1/2	3/8	6	3/8	1 1/2	1	5/16	5/16	1.84	3 3/8	4 1/8	4	2 3/16
2 1/2	3	3/8	6	3/8	1 1/2	1	5/16	5/16	2.19	3 7/8	4 5/8	4 1/8	2 5/16
3 1/4	3 3/4	1/2	10	5/8	1 3/4	1 1/4	3/8	3/8	2.76	4 11/16	5 1/2	4 7/8	2 5/8
4	4 1/2	1/2	10	5/8	1 3/4	1 1/4	3/8	3/8	3.32	5 7/16	6 1/4	4 7/8	2 5/8
5	5 1/2	1/2	10	5/8	1 3/4	1 1/4	7/16	1/2	4.10	6 5/8	7 5/8	5 1/8	2 7/8
6	6 1/2	3/4	12	3/4	2	1 1/2	7/16	1/2	4.88	7 5/8	8 5/8	5 3/4	3 1/8

BORE	ROD DIA.	THREAD		ROD EXTENSIONS AND PILOT DIMENSIONS											ADD STROKE
	MM	KK	CC	A	B †	C	D	V	VG	W	WF	RR	RM	Y	ZJ
1 1/2	5/8	7/16-20	1/2-20	3/4	1 1/8	3/8	1/2	1/4	1/4	5/8	1	3/8	2 3/8	1 31/32	4 5/8
	1 †Ω	3/4-16	7/8-14	1 1/8	1 1/2	1/2	7/8	1/2	3/4	1	1 3/8	5/8	2 1/2	2 11/32	5
2	5/8	7/16-20	1/2-20	3/4	1 1/8	3/8	1/2	1/4	1/4	5/8	1	3/8	2 3/8	1 31/32	4 5/8
	1	3/4-16	7/8-14	1 1/8	1 1/2	1/2	7/8	1/2	3/4	1	1 3/8	5/8	2 1/2	2 11/32	5
2 1/2	1 3/8 †Ω	1-14	1 1/4-12	1 5/8	2	5/8	1 1/8	5/8	7/8	1 1/4	1 5/8	5/8	3 7/32	2 19/32	5 1/4
	5/8	7/16-20	1/2-20	3/4	1 1/8	3/8	1/2	1/4	1/4	5/8	1	3/8	2 3/8	1 31/32	4 3/4
2 1/2	1	3/4-16	7/8-14	1 1/8	1 1/2	1/2	7/8	1/2	3/4	1	1 3/8	3/8	2 1/2	2 11/32	5 1/8
	1 3/8	1-14	1 1/4-12	1 5/8	2	5/8	1 1/8	5/8	7/8	1 1/4	1 5/8	5/8	3 7/32	2 19/32	5 3/8
3 1/4	1 3/4 †Ω	1 1/4-12	1 1/2-12	2	2 3/8	3/4	1 1/2	3/4	1	1 1/2	1 7/8	5/8	3 7/8	2 27/32	5 5/8
	1	3/4-16	7/8-14	1 1/8	1 1/2	1/2	7/8	1/4	1/4	3/4	1 3/8	5/8	2 1/2	2 7/16	5 5/8
3 1/4	1 3/8	1-14	1 1/4-12	1 5/8	2	5/8	1 1/8	3/8	3/8	1	1 5/8	5/8	3 7/32	2 11/16	5 7/8
	1 3/4	1 1/4-12	1 1/2-12	2	2 3/8	3/4	1 1/2	1/2	1/2	1 1/4	1 7/8	5/8	3 7/8	2 15/16	6 1/8
4	2 †	1 1/2-12	1 3/4-12	2 1/4	2 5/8	7/8	1 3/4	1/2	1/2	1 3/8	2	5/8	4	3 1/16	6 1/4
	1	3/4-16	7/8-14	1 1/8	1 1/2	1/2	7/8	1/4	1/4	3/4	1 3/8	5/8	2 1/2	2 7/16	5 5/8
4	1 3/8	1-14	1 1/4-12	1 5/8	2	5/8	1 1/8	3/8	3/8	1	1 5/8	5/8	3 7/32	2 11/16	5 7/8
	1 3/4	1 1/4-12	1 1/2-12	2	2 3/8	3/4	1 1/2	1/2	1/2	1 1/4	1 7/8	5/8	3 7/8	2 15/16	6 1/8
4	2	1 1/2-12	1 3/4-12	2 1/4	2 5/8	7/8	1 3/4	1/2	1/2	1 3/8	2	5/8	4	3 1/16	6 1/4
	2 1/2 †	1 7/8-12	2 1/4-12	3	3 1/8	1	2 1/8	5/8	5/8	1 5/8	2 1/4	5/8	2 1/2	3 5/16	6 1/2
5	1	3/4-16	7/8-14	1 1/8	1 1/2	1/2	7/8	1/4	1/4	3/4	1 3/8	5/8	2 5/8	2 7/16	5 7/8
	1 3/8	1-14	1 1/4-12	1 5/8	2	5/8	1 1/8	3/8	3/8	1	1 5/8	5/8	3 7/32	2 11/16	6 1/8
5	1 3/4	1 1/4-12	1 1/2-12	2	2 3/8	3/4	1 1/2	1/2	1/2	1 1/4	1 7/8	5/8	3 7/8	2 15/16	6 3/8
	2	1 1/2-12	1 3/4-12	2 1/4	2 5/8	7/8	1 3/4	1/2	1/2	1 3/8	2	5/8	4	3 1/16	6 1/2
5	2 1/2	1 7/8-12	2 1/4-12	3	3 1/8	1	2 1/8	5/8	5/8	1 5/8	2 1/4	5/8	4 7/16	3 5/16	6 3/4
	3	2 1/4-12	2 3/4-12	3 1/2	3 3/4	1	2 5/8	5/8	3/4	1 5/8	2 1/4	3/4	5 1/4	3 5/16	6 3/4
6	3 1/2 †	2 1/2-12	3 1/4-12	3 1/2	4 1/4	1	3	5/8	3/4	1 5/8	2 1/4	5/8	5 5/8	3 5/16	6 3/4
	1 3/8	1-14	1 1/4-12	1 5/8	2	5/8	1 1/8	1/4	1/8	7/8	1 5/8	5/8	3 7/32	2 13/16	6 5/8
6	1 3/4	1 1/4-12	1 1/2-12	2	2 3/8	3/4	1 1/2	3/8	1/4	1 1/8	1 7/8	5/8	3 7/8	3 1/16	6 7/8
	2	1 1/2-12	1 3/4-12	2 1/4	2 5/8	7/8	1 3/4	3/8	1/4	1 1/4	2	5/8	4	3 3/16	7
6	2 1/2	1 7/8-12	2 1/4-12	3	3 1/8	1	2 1/8	1/2	3/8	1 1/2	2 1/4	5/8	4 7/16	3 7/16	7 1/4
	3	2 1/4-12	2 3/4-12	3 1/2	3 3/4	1	2 5/8	1/2	1/2	1 1/2	2 1/4	3/4	5 1/4	3 7/16	7 1/4
6	3 1/2	2 1/2-12	3 1/4-12	3 1/2	4 1/4	1	3	1/2	1/2	1 1/2	2 1/4	3/4	5 5/8	3 7/16	7 1/4
	4	3-12	3 3/4-12	4	4 3/4	1	Δ	1/2	5/8	1 1/2	2 1/4	5/8	6 7/16	3 7/16	7 1/4

† HEAD END PORTS SHALLOW TAPPED
Ω FIXED CUSHIONS FURNISHED AT THE HEAD END IN THESE SIZES
Δ (4) SPANNER HOLES USED INSTEAD OF FLATS ON 4" DIA. AND LARGER RODS
§ THESE CYLINDERS HAVE FULL PLATE RETAINERS. USE "E" DIMENSION INSTEAD OF "RM" - SEE PAGE 42
‡ B DIMENSION TOLERANCE -.001/-.003



HEAD SQUARE INTEGRAL FLANGE MOUNT

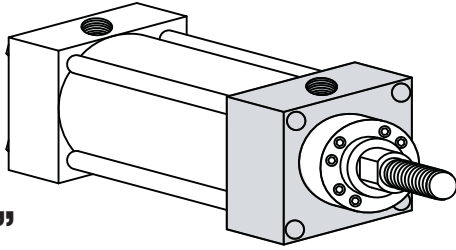

“X”
YATES STYLE X
NFPA-ME3

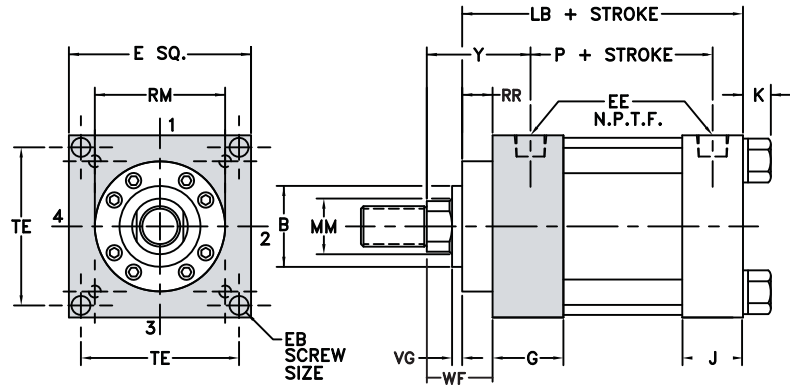

CAP SQUARE INTEGRAL FLANGE MOUNT

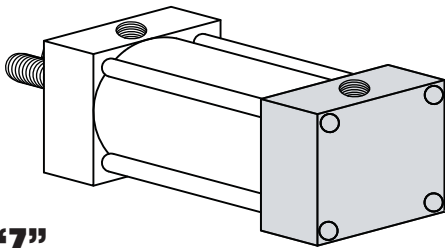

“Z”
YATES STYLE Z
NFPA-ME4

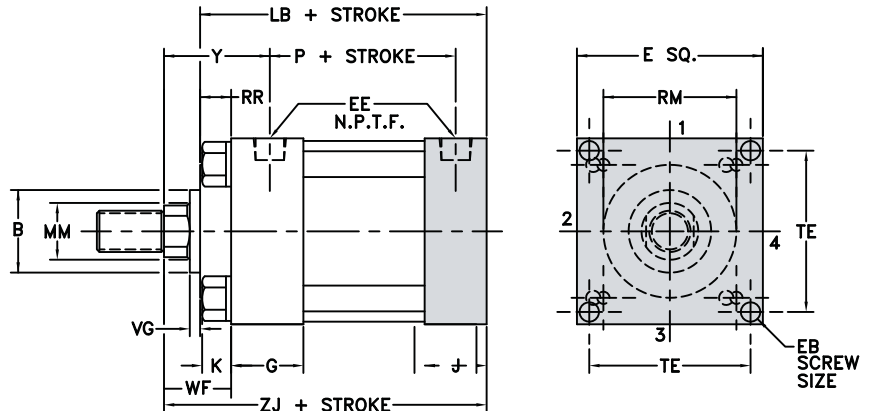

STANDARD ROD ENDS

#2 STD MALE
NFPA-SM

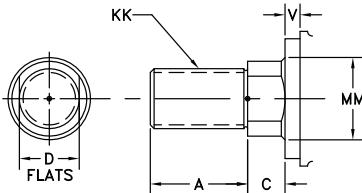

#4 STD FEMALE
NFPA-SF

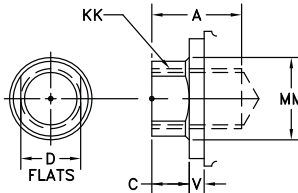

#1 MALE
NFPA-IM

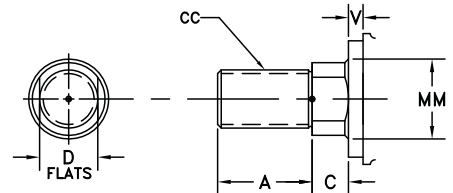

BORE	SAE									ADD STROKE	
	E	EE	OPT	F	G	J	K	EB	TE	LB	P
8	8 1/2	3/4	12	3/4	2	1 1/2	9/16	5/8	7.57	5 7/8	3 1/4

BORE	ROD DIA.		THREAD		ROD EXTENSIONS AND PILOT DIMENSIONS										ADD STROKE
	MM	KK	CC	A	B ±	C	D	V	VG	W	WF	Y	RR	RM	
8	1 3/8	1-14	1 1/4-12	1 5/8	2	5/8	1 1/8	1/4	1/8	7/8	1 5/8	2 13/16	5/8	3 7/32	6 3/4
	1 3/4	1 1/4-12	1 1/2-12	2	2 3/8	3/4	1 1/2	3/8	1/4	1 1/8	1 7/8	3 1/16	5/8	3 7/8	7
	2	1 1/2-12	1 3/4-12	2 1/4	2 5/8	7/8	1 3/4	3/8	1/4	1 1/4	2	3 3/16	5/8	4	7 1/8
	2 1/2	1 7/8-12	2 1/4-12	3	3 1/8	1	2 1/8	1/2	3/8	1 1/2	2 1/4	3 7/16	5/8	4 7/16	7 3/8
	3	2 1/4-12	2 3/4-12	3 1/2	3 3/4	1	2 5/8	1/2	1/2	1 1/2	2 1/4	3 7/16	3/4	5 1/4	7 3/8
	3 1/2	2 1/2-12	3 1/4-12	3 1/2	4 1/4	1	3	1/2	1/2	1 1/2	2 1/4	3 7/16	3/4	5 5/8	7 3/8
	4	3-12	3 3/4-12	4	4 3/4	1	Δ	1/2	5/8	1 1/2	2 1/4	3 7/16	7/8	6 7/16	7 3/8
	4 1/2	3 1/4-12	4 1/4-12	4 1/2	5 1/4	1	Δ	1/2	5/8	1 1/2	2 1/4	3 7/16	7/8	7 1/8	7 3/8
	5	3 1/2-12	4 3/4-12	5	5 3/4	1	Δ	1/2	5/8	1 1/2	2 1/4	3 7/16	7/8	7 5/8	7 3/8

BORE	SAE									ADD STROKE	
	E	EE	OPT	F	G	J	K	EB	TE	LB	P
10	10 5/8	1	16	3/4	2 1/4	2	11/16	3/4	9.40	7 1/8	4 1/8
12	12 3/4	1	16	3/4	2 1/4	2	11/16	3/4	11.10	7 5/8	4 5/8
14	14 3/4	1 1/4	20	3/4	2 3/4	2 1/4	13/16	7/8	12.87	8 7/8	5 1/2
16	17 1/2	1 1/2	24	3/4	2 15/16	2 15/16	15/16	1 1/4	14.75	10	6 1/2
18	19 1/2	1 1/2	24	7/8	3 7/16	3 7/16	1	1 1/2	16.50	11 1/8	6 1/2
20	21 3/4	2	32	7/8	3 15/16	3 15/16	1 1/8	1 3/4	18.25	12 5/8	7 3/8

BORE	ROD DIA.	THREAD		ROD EXTENSIONS AND PILOT DIMENSIONS											ADD STROKE
	MM	KK	CC	A	B \ddagger	C	D	V	VG	W	WF	Y	RR	RM	ZJ
10	1 3/4	1 1/4-12	1 1/2-12	2	2 3/8	3/4	1 1/2	3/8	1/4	1 1/8	1 7/8	3 1/8	5/8	3 7/8	8 1/4
	2	1 1/2-12	1 3/4-12	2 1/4	2 5/8	7/8	1 3/4	3/8	1/4	1 1/4	2	3 1/4	5/8	4	8 3/8
	2 1/2	1 7/8-12	2 1/4-12	3	3 1/8	1	2 1/8	1/2	3/8	1 1/2	2 1/4	3 1/2	5/8	4 7/16	8 5/8
	3	2 1/4-12	2 3/4-12	3 1/2	3 3/4	1	2 5/8	1/2	1/2	1 1/2	2 1/4	3 1/2	3/4	5 1/4	8 5/8
	3 1/2	2 1/2-12	3 1/4-12	3 1/2	4 1/4	1	3	1/2	1/2	1 1/2	2 1/4	3 1/2	3/4	5 5/8	8 5/8
	4	3-12	3 3/4-12	4	4 3/4	1	Δ	1/2	5/8	1 1/2	2 1/4	3 1/2	7/8	6 7/16	8 5/8
	4 1/2	3 1/4-12	4 1/4-12	4 1/2	5 1/4	1	Δ	1/2	5/8	1 1/2	2 1/4	3 1/2	7/8	7 1/8	8 5/8
	5	3 1/2-12	4 3/4-12	5	5 3/4	1	Δ	1/2	5/8	1 1/2	2 1/4	3 1/2	7/8	7 5/8	8 5/8
5 1/2	4-12	5 1/4-12	5 1/2	6 1/4	1	Δ	1/2	5/8	1 1/2	2 1/4	3 1/2	7/8	8 3/8	8 5/8	
12	2	1 1/2-12	1 3/4-12	2 1/4	2 5/8	7/8	1 3/4	3/8	1/4	1 1/4	2	3 1/4	5/8	4	8 7/8
	2 1/2	1 7/8-12	2 1/4-12	3	3 1/8	1	2 1/8	1/2	3/8	1 1/2	2 1/4	3 1/2	5/8	4 7/16	9 1/8
	3	2 1/4-12	2 3/4-12	3 1/2	3 3/4	1	2 5/8	1/2	1/2	1 1/2	2 1/4	3 1/2	3/4	5 1/4	9 1/8
	3 1/2	2 1/2-12	3 1/4-12	3 1/2	4 1/4	1	3	1/2	1/2	1 1/2	2 1/4	3 1/2	3/4	5 5/8	9 1/8
	4	3-12	3 3/4-12	4	4 3/4	1	Δ	1/2	5/8	1 1/2	2 1/4	3 1/2	7/8	6 7/16	9 1/8
	4 1/2	3 1/4-12	4 1/4-12	4 1/2	5 1/4	1	Δ	1/2	5/8	1 1/2	2 1/4	3 1/2	7/8	7 1/8	9 1/8
	5	3 1/2-12	4 3/4-12	5	5 3/4	1	Δ	1/2	5/8	1 1/2	2 1/4	3 1/2	7/8	7 5/8	9 1/8
	5 1/2	4-12	5 1/4-12	5 1/2	6 1/4	1	Δ	1/2	5/8	1 1/2	2 1/4	3 1/2	7/8	8 3/8	9 1/8
14	2 1/2	1 7/8-12	2 1/4-12	3	3 1/8	1	2 1/8	1/2	3/8	1 1/2	2 1/4	3 13/16	5/8	4 7/16	10 3/8
	3	2 1/4-12	2 3/4-12	3 1/2	3 3/4	1	2 5/8	1/2	1/2	1 1/2	2 1/4	3 13/16	3/4	5 1/4	10 3/8
	3 1/2	2 1/2-12	3 1/4-12	3 1/2	4 1/4	1	3	1/2	1/2	1 1/2	2 1/4	3 13/16	3/4	5 5/8	10 3/8
	4	3-12	3 3/4-12	4	4 3/4	1	Δ	1/2	5/8	1 1/2	2 1/4	3 13/16	7/8	6 7/16	10 3/8
	4 1/2	3 1/4-12	4 1/4-12	4 1/2	5 1/4	1	Δ	1/2	5/8	1 1/2	2 1/4	3 13/16	7/8	7 1/8	10 3/8
	5	3 1/2-12	4 3/4-12	5	5 3/4	1	Δ	1/2	5/8	1 1/2	2 1/4	3 13/16	7/8	7 5/8	10 3/8
	5 1/2	4-12	5 1/4-12	5 1/2	6 1/4	1	Δ	1/2	5/8	1 1/2	2 1/4	3 13/16	7/8	8 3/8	10 3/8
	16	3 1/2	2 1/2-12	3 1/4-12	3 1/2	4 1/4	1	3	1/2	1/2	1 1/2	2 1/4	3 5/8	3/4	5 5/8
4	3-12	3 3/4-12	4	4 3/4	1	Δ	1/2	5/8	1 1/2	2 1/4	3 5/8	7/8	6 7/16	11 1/2	
4 1/2	3 1/4-12	4 1/4-12	4 1/2	5 1/4	1	Δ	1/2	5/8	1 1/2	2 1/4	3 5/8	7/8	7 1/8	11 1/2	
5	3 1/2-12	4 3/4-12	5	5 3/4	1	Δ	1/2	5/8	1 1/2	2 1/4	3 5/8	7/8	7 5/8	11 1/2	
5 1/2	4-12	5 1/4-12	5 1/2	6 1/4	1	Δ	1/2	5/8	1 1/2	2 1/4	3 5/8	7/8	8 3/8	11 1/2	
18	4	3-12	3 3/4-12	4	4 3/4	1	Δ	3/8	3/8	1 3/8	2 1/4	4 1/8	7/8	6 7/16	12 1/2
	4 1/2	3 1/4-12	4 1/4-12	4 1/2	5 1/4	1	Δ	3/8	3/8	1 3/8	2 1/4	4 1/8	7/8	7 1/8	12 1/2
	5	3 1/2-12	4 3/4-12	5	5 3/4	1	Δ	3/8	3/8	1 3/8	2 1/4	4 1/8	7/8	7 5/8	12 1/2
	5 1/2	4-12	5 1/4-12	5 1/2	6 1/4	1	Δ	3/8	3/8	1 3/8	2 1/4	4 1/8	7/8	8 3/8	12 1/2
20	4	3-12	3 3/4-12	4	4 3/4	1	Δ	3/8	3/8	1 3/8	2 1/4	4 7/16	7/8	6 7/16	14
	4 1/2	3 1/4-12	4 1/4-12	4 1/2	5 1/4	1	Δ	3/8	3/8	1 3/8	2 1/4	4 7/16	7/8	7 1/8	14
	5	3 1/2-12	4 3/4-12	5	5 3/4	1	Δ	3/8	3/8	1 3/8	2 1/4	4 7/16	7/8	7 5/8	14
	5 1/2	4-12	5 1/4-12	5 1/2	6 1/4	1	Δ	3/8	3/8	1 3/8	2 1/4	4 7/16	7/8	8 3/8	14

Δ (4) SPANNER HOLES USED INSTEAD OF FLATS ON 4" DIA. AND LARGER RODS

\ddagger B DIMENSION TOLERANCE -.001/- .003



NO TIE RODS EXTENDED MOUNT

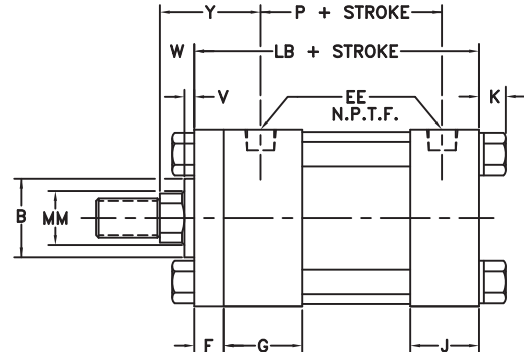
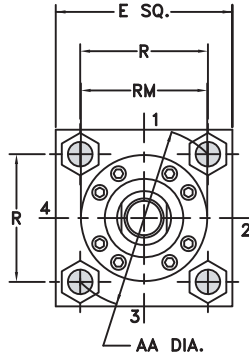
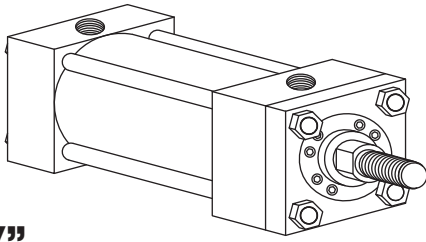

“K”

YATES STYLE **K**
NFPA-MX0

BOTH ENDS TIE RODS EXTENDED MOUNT

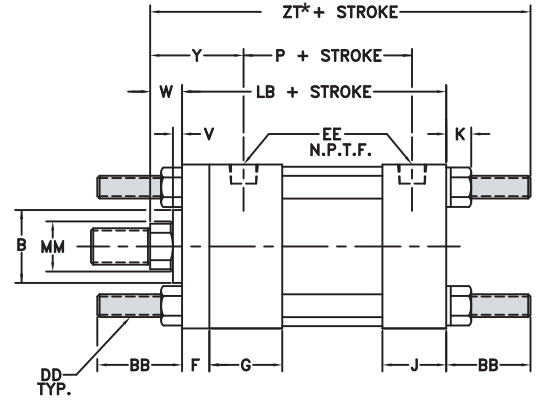
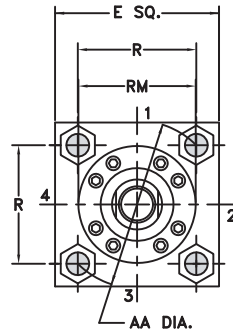
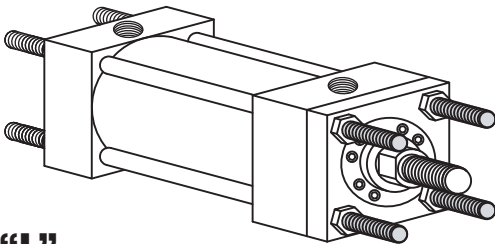

“L”

YATES STYLE **L**
NFPA-MX1

HEAD TIE RODS EXTENDED MOUNT

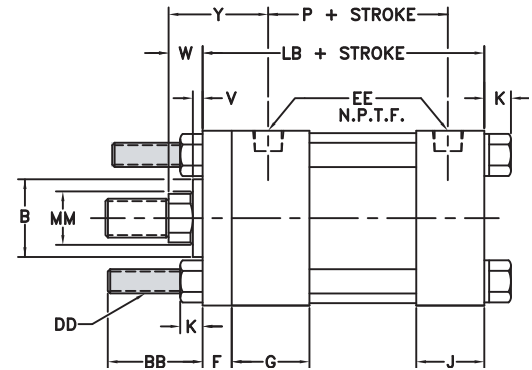
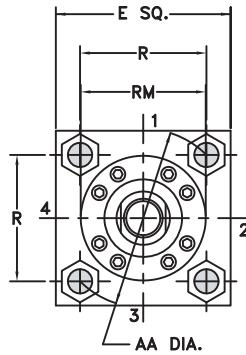
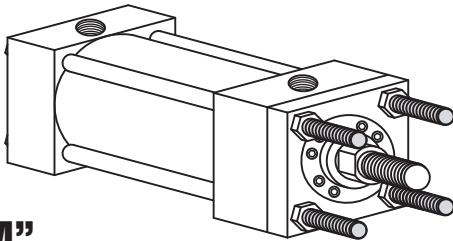

“M”

YATES STYLE **M**
NFPA-MX3

CAP TIE RODS EXTENDED MOUNT

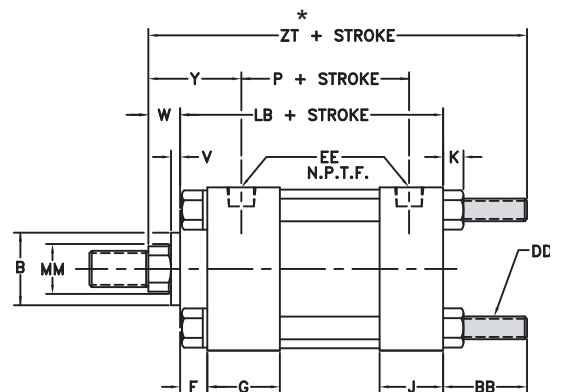
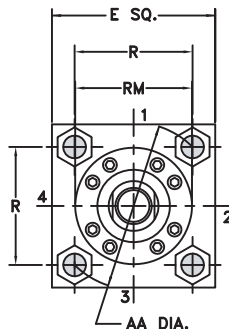
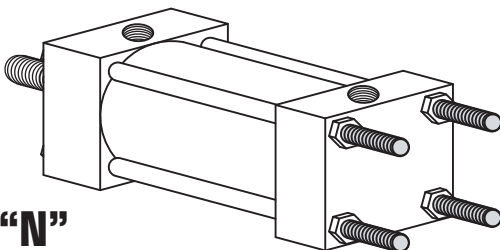

“N”

YATES STYLE **N**
NFPA-MX2

STANDARD ROD ENDS

#2 STD MALE NFPA-SM

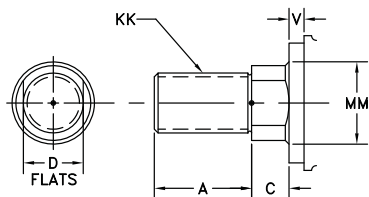

#4 STD FEMALE NFPA-SF

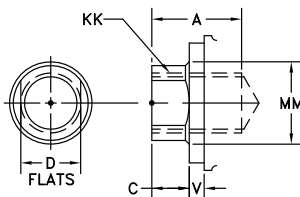

#1 MALE NFPA-IM

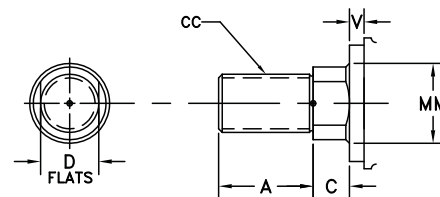

BORE	SAE											ADD STROKE	
	E	EE	OPT	F	G	J	K	AA	BB	DD	R	LB	P
1 1/2	2	3/8	6	3/8	1 1/2	1	1/4	2.02	1	1/4-28	1.43	4	2 3/16
2	2 1/2	3/8	6	3/8	1 1/2	1	5/16	2.60	1 1/8	5/16-24	1.84	4	2 3/16
2 1/2	3	3/8	6	3/8	1 1/2	1	5/16	3.10	1 1/8	5/16-24	2.19	4 1/8	2 5/16
3 1/4	3 3/4	1/2	10	5/8	1 3/4	1 1/4	3/8	3.90	1 3/8	3/8-24	2.76	4 7/8	2 5/8
4	4 1/2	1/2	10	5/8	1 3/4	1 1/4	3/8	4.70	1 3/8	3/8-24	3.32	4 7/8	2 5/8
5	5 1/2	1/2	10	5/8	1 3/4	1 1/4	7/16	5.80	1 13/16	1/2-20	4.10	5 1/8	2 7/8
6	6 1/2	3/4	12	3/4	2	1 1/2	7/16	6.90	1 13/16	1/2-20	4.88	5 3/4	3 1/8

BORE	ROD DIA.		THREAD		ROD EXTENSIONS AND PILOT DIMENSION							ADD STROKE
	MM	KK	CC	A	B ‡	C	D	V	W	RM	Y	ZT*
1 1/2	5/8	7/16-20	1/2-20	3/4	1 1/8	3/8	1/2	1/4	5/8	§	1 31/32	5 5/8
	1 †Ω	3/4-16	7/8-14	1 1/8	1 1/2	1/2	7/8	1/2	1	§	2 11/32	6
2	5/8	7/16-20	1/2-20	3/4	1 1/8	3/8	1/2	1/4	5/8	§	1 31/32	5 3/4
	1	3/4-16	7/8-14	1 1/8	1 1/2	1/2	7/8	1/2	1	§	2 11/32	6 1/8
	1 3/8 †Ω	1-14	1 1/4-12	1 5/8	2	5/8	1 1/8	5/8	1 1/4	§	2 19/32	6 3/8
2 1/2	5/8	7/16-20	1/2-20	3/4	1 1/8	3/8	1/2	1/4	5/8	2 3/8	1 31/32	5 7/8
	1	3/4-16	7/8-14	1 1/8	1 1/2	1/2	7/8	1/2	1	2 1/2	2 11/32	6 1/4
	1 3/8	1-14	1 1/4-12	1 5/8	2	5/8	1 1/8	5/8	1 1/4	§	2 19/32	6 1/2
	1 3/4 †Ω	1 1/4-12	1 1/2-12	2	2 3/8	3/4	1 1/2	3/4	1 1/2	§	2 27/32	6 3/4
3 1/4	1	3/4-16	7/8-14	1 1/8	1 1/2	1/2	7/8	1/4	3/4	2 1/2	2 7/16	7
	1 3/8	1-14	1 1/4-12	1 5/8	2	5/8	1 1/8	3/8	1	3 7/32	2 11/16	7 1/4
	1 3/4	1 1/4-12	1 1/2-12	2	2 3/8	3/4	1 1/2	1/2	1 1/4	§	2 15/16	7 1/2
	2 †	1 1/2-12	1 3/4-12	2 1/4	2 5/8	7/8	1 3/4	1/2	1 3/8	§	3 1/16	7 5/8
	4	3/4-16	7/8-14	1 1/8	1 1/2	1/2	7/8	1/4	3/4	2 1/2	2 7/16	7
4	1 3/8	1-14	1 1/4-12	1 5/8	2	5/8	1 1/8	3/8	1	3 7/32	2 11/16	7 1/4
	1 3/4	1 1/4-12	1 1/2-12	2	2 3/8	3/4	1 1/2	1/2	1 1/4	3 7/8	2 15/16	7 1/2
	2	1 1/2-12	1 3/4-12	2 1/4	2 5/8	7/8	1 3/4	1/2	1 3/8	4	3 1/16	7 5/8
	2 1/2 †	1 7/8-12	2 1/4-12	3	3 1/8	1	2 1/8	5/8	1 5/8	§	3 5/16	7 7/8
	5	3/4-16	7/8-14	1 1/8	1 1/2	1/2	7/8	1/4	3/4	3 7/8	2 7/16	7 11/16
	1 3/8	1-14	1 1/4-12	1 5/8	2	5/8	1 1/8	3/8	1	3 7/32	2 11/16	7 15/16
5	1 3/4	1 1/4-12	1 1/2-12	2	2 3/8	3/4	1 1/2	1/2	1 1/4	3 7/8	2 15/16	8 3/16
	2	1 1/2-12	1 3/4-12	2 1/4	2 5/8	7/8	1 3/4	1/2	1 3/8	4	3 1/16	8 5/16
	2 1/2	1 7/8-12	2 1/4-12	3	3 1/8	1	2 1/8	5/8	1 5/8	4 7/16	3 5/16	8 9/16
	3	2 1/4-12	2 3/4-12	3 1/2	3 3/4	1	2 5/8	5/8	1 5/8	§	3 5/16	8 9/16
	3 1/2 †	2 1/2-12	3 1/4-12	3 1/2	4 1/4	1	3	5/8	1 5/8	§	3 5/16	8 9/16
	6	3/4-16	7/8-14	1 1/8	1 1/2	1/2	7/8	1/4	3/4	3 7/8	2 7/16	7 11/16
	1 3/8	1-14	1 1/4-12	1 5/8	2	5/8	1 1/8	3/8	1	3 7/32	2 11/16	7 15/16
6	1 3/4	1 1/4-12	1 1/2-12	2	2 3/8	3/4	1 1/2	1/2	1 1/4	3 7/8	2 15/16	8 3/16
	2	1 1/2-12	1 3/4-12	2 1/4	2 5/8	7/8	1 3/4	1/2	1 3/8	4	3 1/16	8 5/16
	2 1/2	1 7/8-12	2 1/4-12	3	3 1/8	1	2 1/8	5/8	1 5/8	4 7/16	3 5/16	8 9/16
	3	2 1/4-12	2 3/4-12	3 1/2	3 3/4	1	2 5/8	5/8	1 5/8	§	3 5/16	8 9/16
	3 1/2 †	2 1/2-12	3 1/4-12	3 1/2	4 1/4	1	3	5/8	1 5/8	§	3 5/16	8 9/16
	4	3/4-16	7/8-14	1 1/8	1 1/2	1/2	7/8	1/4	3/4	3 7/8	2 7/16	7 11/16
	1 3/8	1-14	1 1/4-12	1 5/8	2	5/8	1 1/8	3/8	1	3 7/32	2 11/16	7 15/16
	1 3/4	1 1/4-12	1 1/2-12	2	2 3/8	3/4	1 1/2	1/2	1 1/4	3 7/8	2 15/16	8 3/16
6	2	1 1/2-12	1 3/4-12	2 1/4	2 5/8	7/8	1 3/4	1/2	1 3/8	4	3 1/16	8 5/16
	2 1/2	1 7/8-12	2 1/4-12	3	3 1/8	1	2 1/8	5/8	1 5/8	4 7/16	3 5/16	8 9/16
	3	2 1/4-12	2 3/4-12	3 1/2	3 3/4	1	2 5/8	5/8	1 5/8	§	3 5/16	8 9/16
	3 1/2 †	2 1/2-12	3 1/4-12	3 1/2	4 1/4	1	3	5/8	1 5/8	§	3 5/16	8 9/16
	4	3/4-16	7/8-14	1 1/8	1 1/2	1/2	7/8	1/4	3/4	3 7/8	2 7/16	7 11/16
	1 3/8	1-14	1 1/4-12	1 5/8	2	5/8	1 1/8	3/8	1	3 7/32	2 11/16	7 15/16
	1 3/4	1 1/4-12	1 1/2-12	2	2 3/8	3/4	1 1/2	1/2	1 1/4	3 7/8	2 15/16	8 3/16
	2	1 1/2-12	1 3/4-12	2 1/4	2 5/8	7/8	1 3/4	1/2	1 3/8	4	3 1/16	8 5/16
	2 1/2	1 7/8-12	2 1/4-12	3	3 1/8	1	2 1/8	5/8	1 5/8	4 7/16	3 5/16	8 9/16
3	2 1/4-12	2 3/4-12	3 1/2	3 3/4	1	2 5/8	5/8	1 5/8	§	3 5/16	8 9/16	
3 1/2 †	2 1/2-12	3 1/4-12	3 1/2	4 1/4	1	3	5/8	1 5/8	§	3 5/16	8 9/16	
4	3-12	3 3/4-12	4	4 3/4	1	Δ	1/2	1 1/2	§	3 7/16	9 1/16	

† HEAD END PORTS SHALLOW TAPPED

Ω FIXED CUSHIONS FURNISHED AT THE HEAD END IN THESE SIZES

§ THESE CYLINDERS HAVE FULL PLATE RETAINERS. USE "E" DIMENSION INSTEAD OF "RM" - SEE PAGE 42

* ZT DIMENSION CHANGES ON DOUBLE ROD CYLINDERS - SEE PAGE 72 FOR DETAILS

NOTE: 1 1/2" AND 2" BORE CYLINDERS ON K AND N MOUNTS AND 1 1/2" THRU 6" BORE CYLINDERS ON L AND M MOUNTS HAVE FULL PLATE RETAINERS. USE "E" SQ. DIMENSION INSTEAD OF "RM"



NO TIE RODS EXTENDED MOUNT

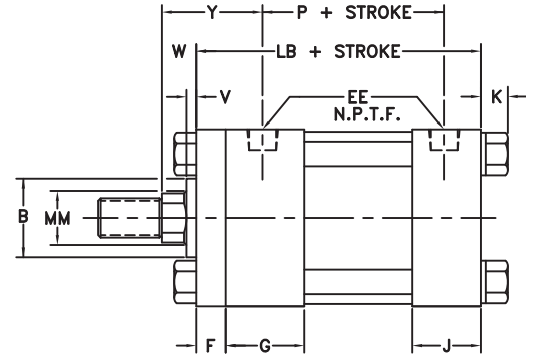
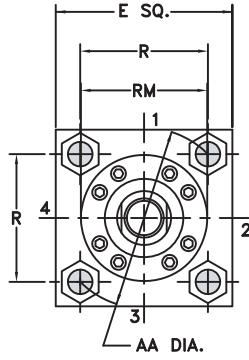
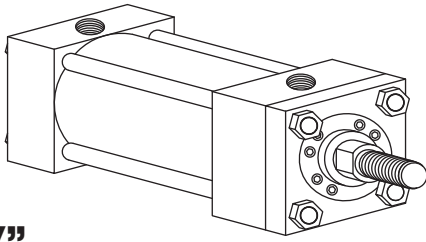

“K”

YATES STYLE **K**
NFPA-MX0

BOTH ENDS TIE RODS EXTENDED MOUNT

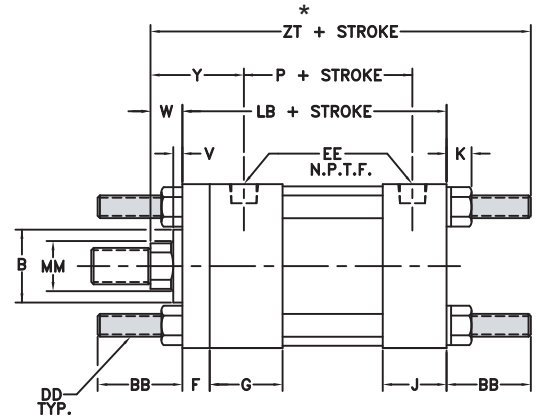
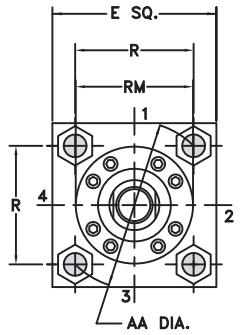
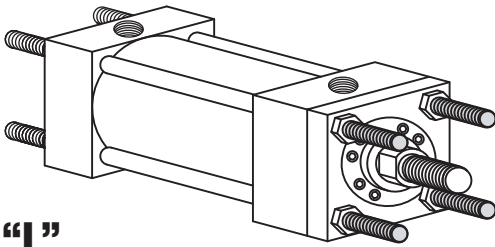

“L”

YATES STYLE **L**
NFPA-MX1

HEAD TIE RODS EXTENDED MOUNT

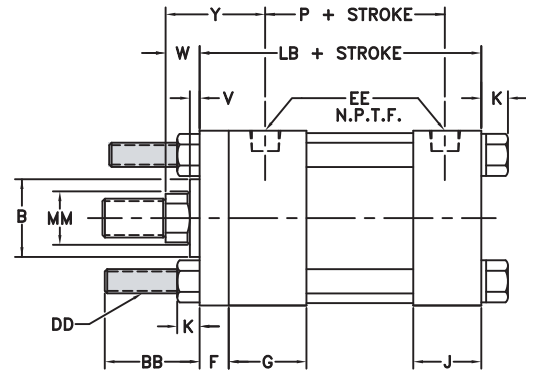
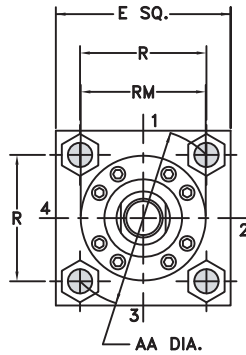
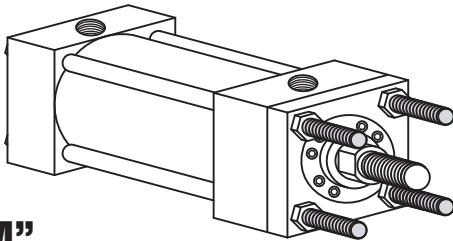

“M”

YATES STYLE **M**
NFPA-MX3

CAP TIE RODS EXTENDED MOUNT

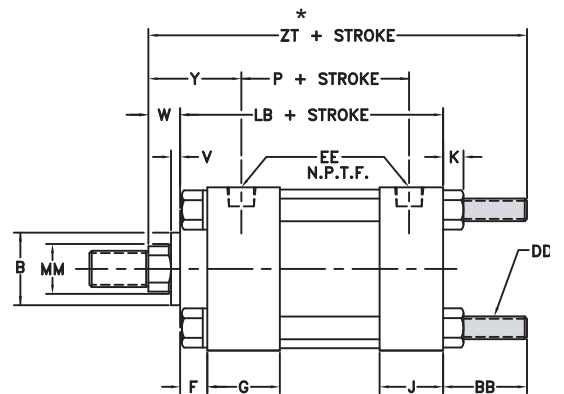
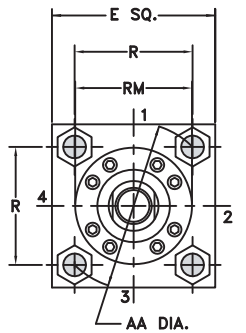
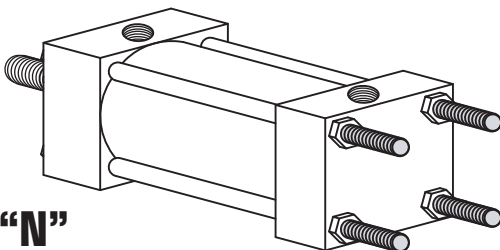

“N”

YATES STYLE **N**
NFPA-MX2

SERIES A4/L4/H4

MI 586.778.7680
AL 256.351.8081



BORE	SAE											ADD STROKE	
	E	EE	OPT	F	G	J	K	AA	BB	DD	R	LB	P
8	8 1/2	3/4	12	3/4	2	1 1/2	9/16	9.11	2 5/16	5/8-18	6.44	5 7/8	3 1/4
10	10 5/8	1	16	3/4	2 1/4	2	11/16	11.20	2 11/16	3/4-16	7.92	7 1/8	4 1/8
12	12 3/4	1	16	3/4	2 1/4	2	11/16	13.29	2 11/16	3/4-16	9.40	7 5/8	4 5/8
14	14 3/4	1 1/4	20	3/4	2 3/4	2 1/4	13/16	15.41	3 3/16	7/8-14	10.90	8 7/8	5 1/2
16	17 1/2	1 1/2	24	3/4	2 15/16	2 15/16	15/16	18.25	3 5/8	1-14	Φ	10	6 1/2
18	19 1/2	1 1/2	24	7/8	3 7/16	3 7/16	1	20.50	4 1/8	1 1/8-12	Φ	11 1/8	6 1/2
20	21 3/4	2	32	7/8	3 15/16	3 15/16	1 1/8	22.62	4 1/2	1 1/4-12	Φ	12 5/8	7 3/8

BORE	ROD DIA.	THREAD		ROD EXTENSIONS AND PILOT DIMENSION								ADD STROKE	
	MM	KK	CC	A	B ‡	C	D	V	W	RM	Y	ZT*	
8	1 3/8	1-14	1 1/4-12	1 5/8	2	5/8	1 1/8	1/4	7/8	3 7/32	2 13/16	9 1/16	
	1 3/4	1 1/4-12	1 1/2-12	2	2 3/8	3/4	1 1/2	3/8	1 1/8	3 7/8	3 1/16	9 5/16	
	2	1 1/2-12	1 3/4-12	2 1/4	2 5/8	7/8	1 3/4	3/8	1 1/4	4	3 3/16	9 7/16	
	2 1/2	1 7/8-12	2 1/4-12	3	3 1/8	1	2 1/8	1/2	1 1/2	4 7/16	3 7/16	9 11/16	
	3	2 1/4-12	2 3/4-12	3 1/2	3 3/4	1	2 5/8	1/2	1 1/2	5 1/4	3 7/16	9 11/16	
	3 1/2	2 1/2-12	3 1/4-12	3 1/2	4 1/4	1	3	1/2	1 1/2	5 5/8	3 7/16	9 11/16	
	4	3-12	3 3/4-12	4	4 3/4	1	Δ	1/2	1 1/2	6 7/16	3 7/16	9 11/16	
	4 1/2	3 3/4-12	4 1/4-12	4 1/2	5 1/4	1	Δ	1/2	1 1/2	7 1/8	3 7/16	9 11/16	
	5	3 1/2-12	4 3/4-12	5	5 3/4	1	Δ	1/2	1 1/2	7 5/8	3 7/16	9 11/16	
	10	1 3/4	1 1/4-12	1 1/2-12	2	2 3/8	3/4	1 1/2	3/8	1 1/8	3 7/8	3 1/8	10 15/16
2		1 1/2-12	1 3/4-12	2 1/4	2 5/8	7/8	1 3/4	3/8	1 1/4	4	3 1/4	11 1/16	
2 1/2		1 7/8-12	2 1/4-12	3	3 1/8	1	2 1/8	1/2	1 1/2	4 7/16	3 1/2	11 5/16	
3		2 1/4-12	2 3/4-12	3 1/2	3 3/4	1	2 5/8	1/2	1 1/2	5 1/4	3 1/2	11 5/16	
3 1/2		2 1/2-12	3 1/4-12	3 1/2	4 1/4	1	3	1/2	1 1/2	5 5/8	3 1/2	11 5/16	
4		3-12	3 3/4-12	4	4 3/4	1	Δ	1/2	1 1/2	6 7/16	3 1/2	11 5/16	
4 1/2		3 1/4-12	4 1/4-12	4 1/2	5 1/4	1	Δ	1/2	1 1/2	7 1/8	3 1/2	11 5/16	
5		3 1/2-12	4 3/4-12	5	5 3/4	1	Δ	1/2	1 1/2	7 5/8	3 1/2	11 5/16	
5 1/2		4-12	5 1/4-12	5 1/2	6 1/4	1	Δ	1/2	1 1/2	8 3/8	3 1/2	11 5/16	
12		2	1 1/2-12	1 3/4-12	2 1/4	2 5/8	7/8	1 3/4	3/8	1 1/4	4	3 1/4	11 9/16
	2 1/2	1 7/8-12	2 1/4-12	3	3 1/8	1	2 1/8	1/2	1 1/2	4 7/16	3 1/2	11 13/16	
	3	2 1/4-12	2 3/4-12	3 1/2	3 3/4	1	2 5/8	1/2	1 1/2	5 1/4	3 1/2	11 13/16	
	3 1/2	2 1/2-12	3 1/4-12	3 1/2	4 1/4	1	3	1/2	1 1/2	5 5/8	3 1/2	11 13/16	
	4	3-12	3 3/4-12	4	4 3/4	1	Δ	1/2	1 1/2	6 7/16	3 1/2	11 13/16	
	4 1/2	3 1/4-12	4 1/4-12	4 1/2	5 1/4	1	Δ	1/2	1 1/2	7 1/8	3 1/2	11 13/16	
	5	3 1/2-12	4 3/4-12	5	5 3/4	1	Δ	1/2	1 1/2	7 5/8	3 1/2	11 13/16	
	5 1/2	4-12	5 1/4-12	5 1/2	6 1/4	1	Δ	1/2	1 1/2	8 3/8	3 1/2	11 13/16	
	14	2 1/2	1 7/8-12	2 1/4-12	3	3 1/8	1	2 1/8	1/2	1 1/2	4 7/16	3 13/16	13 9/16
		3	2 1/4-12	2 3/4-12	3 1/2	3 3/4	1	2 5/8	1/2	1 1/2	5 1/4	3 13/16	13 9/16
3 1/2		2 1/2-12	3 1/4-12	3 1/2	4 1/4	1	3	1/2	1 1/2	5 5/8	3 13/16	13 9/16	
4		3-12	3 3/4-12	4	4 3/4	1	Δ	1/2	1 1/2	6 7/16	3 13/16	13 9/16	
4 1/2		3 1/4-12	4 1/4-12	4 1/2	5 1/4	1	Δ	1/2	1 1/2	7 1/8	3 13/16	13 9/16	
5		3 1/2-12	4 3/4-12	5	5 3/4	1	Δ	1/2	1 1/2	7 5/8	3 13/16	13 9/16	
5 1/2		4-12	5 1/4-12	5 1/2	6 1/4	1	Δ	1/2	1 1/2	8 3/8	3 13/16	13 9/16	
16		3 1/2	2 1/2-12	3 1/4-12	3 1/2	4 1/4	1	3	1/2	1 1/2	5 5/8	3 5/8	15 1/8
		4	3-12	3 3/4-12	4	4 3/4	1	Δ	1/2	1 1/2	6 7/16	3 5/8	15 1/8
		4 1/2	3 1/4-12	4 1/4-12	4 1/2	5 1/4	1	Δ	1/2	1 1/2	7 1/8	3 5/8	15 1/8
	5	3 1/2-12	4 3/4-12	5	5 3/4	1	Δ	1/2	1 1/2	7 5/8	3 5/8	15 1/8	
	5 1/2	4-12	5 1/4-12	5 1/2	6 1/4	1	Δ	1/2	1 1/2	8 3/8	3 5/8	15 1/8	
	18	4	3-12	3 3/4-12	4	4 3/4	1	Δ	3/8	1 3/8	6 7/16	4 1/8	16 5/8
		4 1/2	3 1/4-12	4 1/4-12	4 1/2	5 1/4	1	Δ	3/8	1 3/8	7 1/8	4 1/8	16 5/8
		5	3 1/2-12	4 3/4-12	5	5 3/4	1	Δ	3/8	1 3/8	7 5/8	4 1/8	16 5/8
		5 1/2	4-12	5 1/4-12	5 1/2	6 1/4	1	Δ	3/8	1 3/8	8 3/8	4 1/8	16 5/8
		20	4	3-12	3 3/4-12	4	4 3/4	1	Δ	3/8	1 3/8	6 7/16	4 7/16
4 1/2			3 1/4-12	4 1/4-12	4 1/2	5 1/4	1	Δ	3/8	1 3/8	7 1/8	4 7/16	18 1/2
5			3 1/2-12	4 3/4-12	5	5 3/4	1	Δ	3/8	1 3/8	7 5/8	4 7/16	18 1/2
5 1/2			4-12	5 1/4-12	5 1/2	6 1/4	1	Δ	3/8	1 3/8	8 3/8	4 7/16	18 1/2

Δ (4) SPANNER HOLES USED INSTEAD OF FLATS ON 4" DIA. AND LARGER RODS
‡ B DIMENSION TOLERANCE -.001/-.003
Φ FOR 16-20" BORES, SEE PAGE 42 FOR TIE ROD INFORMATION
* ZT DIMENSION CHANGES ON DOUBLE ROD CYLINDERS - SEE PAGE 72 FOR DETAILS



DOUBLE ROD END CYLINDERS

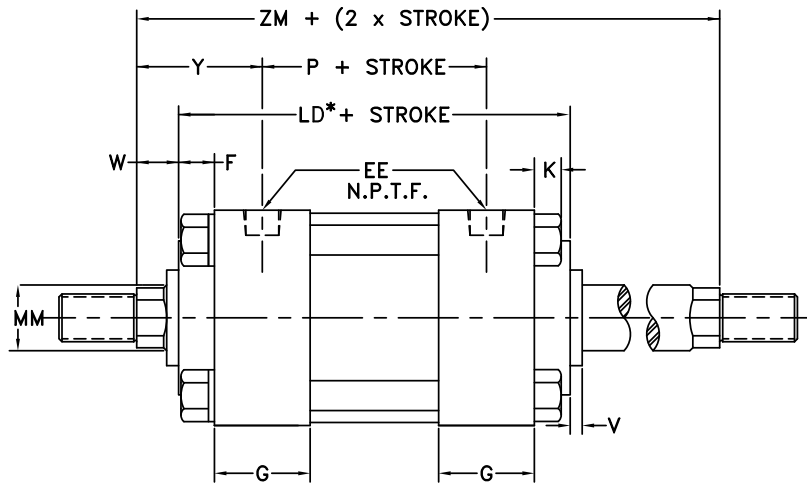
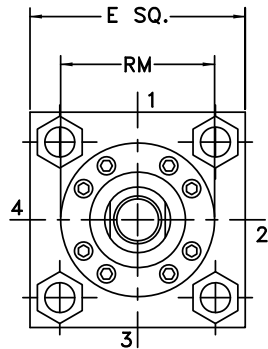

BORE	ROD DIA. MM	ADD STROKE						ADD 2X STROKE ZM
		LD*	SE	SS	XE	ZE	ZT	
1 1/2	5/8	4 7/8	6 3/8	3 3/8	6 1/4	6 1/2	6 1/2	6 1/8
	1	4 7/8	6 3/8	3 3/8	6 5/8	6 7/8	6 7/8	6 7/8
2	5/8	4 7/8	6 3/4	3 3/8	6 7/16	6 3/4	6 5/8	6 1/8
	1	4 7/8	6 3/4	3 3/8	6 13/16	7 1/8	7	6 7/8
	1 3/8	4 7/8	6 3/4	3 3/8	7 1/16	7 3/8	7 1/4	7 3/8
2 1/2	5/8	5	7 1/8	3 1/2	6 11/16	7	6 3/4	6 1/4
	1	5	7 1/8	3 1/2	7 1/16	7 3/8	7 1/8	7
	1 3/8	5	7 1/8	3 1/2	7 5/16	7 5/8	7 3/8	7 1/2
	1 3/4	5	7 1/8	3 1/2	7 9/16	7 7/8	7 5/8	8
3 1/4	1	6	7 3/4	3 3/4	7 5/8	8	8 1/8	7 1/2
	1 3/8	6	7 3/4	3 3/4	7 7/8	8 1/4	8 3/8	8
	1 3/4	6	7 3/4	3 3/4	8 1/8	8 1/2	8 5/8	8 1/2
	2	6	7 3/4	3 3/4	8 1/4	8 5/8	8 3/4	8 3/4
4	1	6	8	3 3/4	7 3/4	8 1/8	8 1/8	7 1/2
	1 3/8	6	8	3 3/4	8	8 3/8	8 3/8	8
	1 3/4	6	8	3 3/4	8 1/4	8 5/8	8 5/8	8 1/2
	2	6	8	3 3/4	8 3/8	8 3/4	8 3/4	8 3/4
	2 1/2	6	8	3 3/4	8 5/8	9	9	9 1/4
	3	6 1/4	8 3/8	3 5/8	8 1/16	8 9/16	8 13/16	7 3/4
5	1 3/8	6 1/4	8 3/8	3 5/8	8 5/16	8 13/16	9 1/16	8 1/4
	1 3/4	6 1/4	8 3/8	3 5/8	8 9/16	9 1/16	9 5/16	8 3/4
	2	6 1/4	8 3/8	3 5/8	8 11/16	9 3/16	9 7/16	9
	2 1/2	6 1/4	8 3/8	3 5/8	8 15/16	9 7/16	9 11/16	9 1/2
	3	6 1/4	8 3/8	3 5/8	8 15/16	9 7/16	9 11/16	9 1/2
	3 1/2	6 1/4	8 3/8	3 5/8	8 15/16	9 7/16	9 11/16	9 1/2
	4	7	9	4 1/8	8 7/8	9 3/8	9 11/16	8 3/4
	4 1/2	7	9	4 1/8	9 1/8	9 5/8	9 15/16	9 1/4
6	2	7	9	4 1/8	9 1/4	9 3/4	10 1/16	9 1/2
	2 1/2	7	9	4 1/8	9 1/2	10	10 5/16	10
	3	7	9	4 1/8	9 1/2	10	10 5/16	10
	3 1/2	7	9	4 1/8	9 1/2	10	10 5/16	10
	4	7	9	4 1/8	9 1/2	10	10 5/16	10
	4 1/2	7	9	4 1/8	9 1/2	10	10 5/16	10
	5	7 1/8	7 7/8	4 1/4	8 3/8	9	9 9/16	8 7/8
	5 1/2	7 1/8	7 7/8	4 1/4	8 5/8	9 1/4	9 13/16	9 3/8
	6	7 1/8	7 7/8	4 1/4	8 3/4	9 3/8	9 15/16	9 5/8
	6 1/2	7 1/8	7 7/8	4 1/4	9	9 5/8	10 3/16	10 1/8
8	3	7 1/8	7 7/8	4 1/4	9	9 5/8	10 3/16	10 1/8
	3 1/2	7 1/8	7 7/8	4 1/4	9	9 5/8	10 3/16	10 1/8
	4	7 1/8	7 7/8	4 1/4	9	9 5/8	10 3/16	10 1/8
	4 1/2	7 1/8	7 7/8	4 1/4	9	9 5/8	10 3/16	10 1/8
	5	7 1/8	7 7/8	4 1/4	9	9 5/8	10 3/16	10 1/8
	5 1/2	7 1/8	7 7/8	4 1/4	9	9 5/8	10 3/16	10 1/8
	6	7 1/8	7 7/8	4 1/4	9	9 5/8	10 3/16	10 1/8
	6 1/2	7 1/8	7 7/8	4 1/4	9	9 5/8	10 3/16	10 1/8

DOUBLE ROD CYLINDERS

AVAILABLE IN MOUNTING STYLES

A, B, E, F, G, H, J, K, L, M, T, U, AND X

ALL DIMENSIONS APPLY TO STANDARD ROD SIZES

* "LD" replaces "LB" dimensions on all styles with double rod ends.

FOR ORDERING DOUBLE ROD END CYLINDERS

ADD "D" AFTER STYLE

Example: Style "A" side lug mount with double rod end is style "A4AD".

Where the two rod ends will be different, state which rod end is to go at which end of cylinder.

If only one end of double rod cylinder is to be cushioned, specify clearly which end.

EXTENDED KEY PLATE MOUNTINGS

FOR ORDERING EXTENDED KEY PLATE add "S" in part # & state extended key plate in description available in mounting styles "A", "B", and "E"

BORE	FA	FE
1 1/2	.362	3/16
2	.362	3/16
2 1/2	.362	3/16
3 1/4	.612	5/16
4	.612	5/16
5	.612	5/16
6	.737	3/8

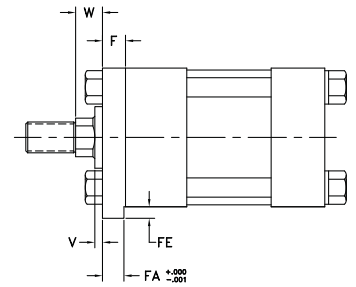

BORE	ROD DIA. MM	ADD STROKE						ADD 2X STROKE ZM
		LD*	SE	SS	XE	ZE	ZT	
10	1 3/4	8 1/8	9 1/4	4 7/8	9 13/16	10 7/16	11 3/16	10 3/8
	2	8 1/8	9 1/4	4 7/8	9 15/16	10 9/16	11 5/16	10 5/8
	2 1/2	8 1/8	9 1/4	4 7/8	10 3/16	10 13/16	11 9/16	11 1/8
	3	8 1/8	9 1/4	4 7/8	10 3/16	10 13/16	11 9/16	11 1/8
	3 1/2	8 1/8	9 1/4	4 7/8	10 3/16	10 13/16	11 9/16	11 1/8
	4	8 1/8	9 1/4	4 7/8	10 3/16	10 13/16	11 9/16	11 1/8
	4 1/2	8 1/8	9 1/4	4 7/8	10 3/16	10 13/16	11 9/16	11 1/8
	5	8 1/8	9 1/4	4 7/8	10 3/16	10 13/16	11 9/16	11 1/8
	5 1/2	8 1/8	9 1/4	4 7/8	10 3/16	10 13/16	11 9/16	11 1/8
12	2	8 5/8	9 3/4	5 3/8	10 7/16	11 1/16	11 13/16	11 1/8
	2 1/2	8 5/8	9 3/4	5 3/8	10 11/16	11 5/16	12 1/16	11 5/8
	3	8 5/8	9 3/4	5 3/8	10 11/16	11 5/16	12 1/16	11 5/8
	3 1/2	8 5/8	9 3/4	5 3/8	10 11/16	11 5/16	12 1/16	11 5/8
	4	8 5/8	9 3/4	5 3/8	10 11/16	11 5/16	12 1/16	11 5/8
	4 1/2	8 5/8	9 3/4	5 3/8	10 11/16	11 5/16	12 1/16	11 5/8
	5	8 5/8	9 3/4	5 3/8	10 11/16	11 5/16	12 1/16	11 5/8
	5 1/2	8 5/8	9 3/4	5 3/8	10 11/16	11 5/16	12 1/16	11 5/8
14	2 1/2	10 1/8	11 5/8	6 3/8	12 3/8	13 1/8	14 1/16	13 1/8
	3	10 1/8	11 5/8	6 3/8	12 3/8	13 1/8	14 1/16	13 1/8
	3 1/2	10 1/8	11 5/8	6 3/8	12 3/8	13 1/8	14 1/16	13 1/8
	4	10 1/8	11 5/8	6 3/8	12 3/8	13 1/8	14 1/16	13 1/8
	4 1/2	10 1/8	11 5/8	6 3/8	12 3/8	13 1/8	14 1/16	13 1/8
	5	10 1/8	11 5/8	6 3/8	12 3/8	13 1/8	14 1/16	13 1/8
	5 1/2	10 1/8	11 5/8	6 3/8	12 3/8	13 1/8	14 1/16	13 1/8
16	3 1/2	10 3/4	NA	5 3/4	NA	NA	15 1/8	13 3/4
	4	10 3/4	NA	5 3/4	NA	NA	15 1/8	13 3/4
	4 1/2	10 3/4	NA	5 3/4	NA	NA	15 1/8	13 3/4
	5	10 3/4	NA	5 3/4	NA	NA	15 1/8	13 3/4
	5 1/2	10 3/4	NA	5 3/4	NA	NA	15 1/8	13 3/4
18	4	12	NA	6 1/4	NA	NA	16 5/8	14 3/4
	4 1/2	12	NA	6 1/4	NA	NA	16 5/8	14 3/4
	5	12	NA	6 1/4	NA	NA	16 5/8	14 3/4
	5 1/2	12	NA	6 1/4	NA	NA	16 5/8	14 3/4
20	4	13 1/2	NA	7	NA	NA	18 1/2	16 1/4
	4 1/2	13 1/2	NA	7	NA	NA	18 1/2	16 1/4
	5	13 1/2	NA	7	NA	NA	18 1/2	16 1/4
	5 1/2	13 1/2	NA	7	NA	NA	18 1/2	16 1/4



FEMALE CLEVIS

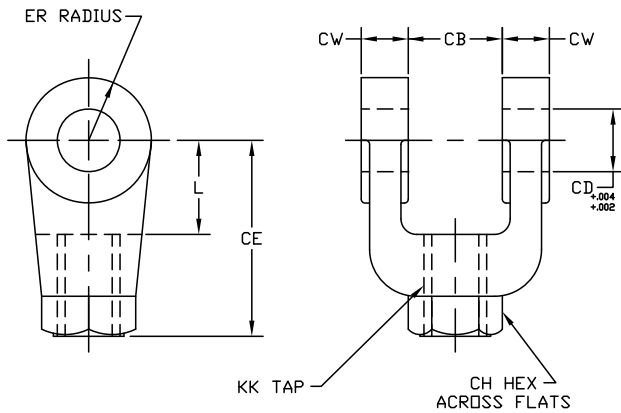

PART NO.	CB	CD	CE	CH	CW	ER	KK	L
10-YFC-134-05-A	3/4	1/2	1 1/2	1	1/2	1/2	7/16-20	3/4
10-YFC-134-08-A	1 1/4	3/4	2 3/8	1 1/4	5/8	3/4	3/4-16	1 1/4
10-YFC-134-08-M	1 1/4	3/4	2 1/8	1 3/8	5/8	3/4	3/4-16	1
10-YFC-134-11-A	1 1/2	1	3 1/8	1 1/2	3/4	1	1-14	1 1/2
10-YFC-134-11-M	1 1/2	1	2 15/16	1 1/2	3/4	1	1-14	1 5/16
10-YFC-134-14-A	2	1 3/8	4 1/8	2	1	1 3/8	1 1/4-12	2 1/8
10-YFC-134-14-M	2	1 3/8	3 3/4	2	1	1 3/8	1 1/4-12	1 3/4
10-YFC-134-16-A	2 1/2	1 3/4	4 1/2	2 3/8	1 1/4	1 3/4	1 1/2-12	2 1/4
10-YFC-134-20-A	2 1/2	2	5 1/2	2 15/16	1 1/4	2	1 7/8-12	2 1/2
10-YFC-134-24-A	3	2 1/2	6 1/2	3 1/2	1 1/2	2 1/2	2 1/4-12	3
10-YFC-134-28-A	3	3	6 3/4	3 7/8	1 1/2	2 3/4	2 1/2-12	3 1/4
10-YFC-134-28-M	3	3	6 3/4	3 7/8	1 1/2	3	2 1/2-12	3 1/4
10-YFC-134-36-A	4	3 1/2	8 1/2	5	2	3 1/2	3 1/4-12	4
10-YFC-134-36-M	4	3 1/2	7 3/4	5	2	3 1/2	3 1/4-12	4 1/4
10-YFC-134-44-A	4 1/2	4	10	6 1/8	2 1/4	4	4-12	4 1/2

ROD COUPLERS

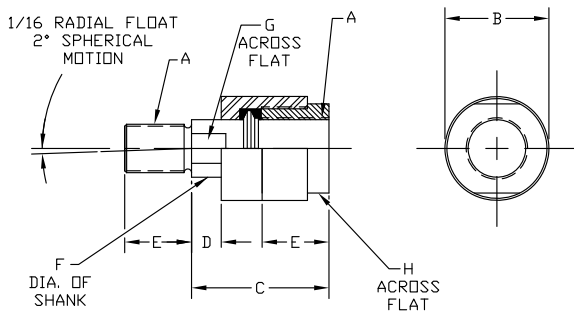

PART NUMBER	ROD DIA.	A	B	C	D	E	F	G	H	MAX PULL
11-YAC-2-05	5/8	7/16-20	1 1/4	2	1/2	3/4	5/8	1/2	1	10,000
11-YAC-2-06	5/8	1/2-20	1 1/4	2	1/2	3/4	5/8	1/2	1	14,000
11-YAC-2-07	5/8	5/8-18	1 1/4	2	1/2	3/4	5/8	1/2	1	19,000
11-YAC-2-08	1	3/4-16	1 3/4	2 5/16	1/2	1 1/8	31/32	13/16	1 1/2	34,000
11-YAC-2-09	1	7/8-14	1 3/4	2 5/16	1/2	1 1/8	31/32	13/16	1 1/2	39,000
11-YAC-2-11	1 3/8	1-14	2 1/2	2 15/16	1/2	1 5/8	1 3/8	1 5/32	2 1/4	64,000
11-YAC-2-14	1 3/8	1 1/4-12	2 1/2	2 15/16	1/2	1 5/8	1 3/8	1 5/32	2 1/4	78,000
11-YAC-2-15	1 3/8	1 3/8-12	2 1/2	2 15/16	1/2	1 5/8	1 3/8	1 5/32	2 1/4	78,000
11-YAC-2-16	2	1 1/2-12	3 1/4	4 3/8	13/16	2 1/4	1 3/4	1 1/2	3	134,000
11-YAC-2-17	2	1 3/4-12	3 1/4	4 3/8	13/16	2 1/4	1 3/4	1 1/2	3	134,000
11-YAC-2-20	2 1/2	1 7/8-12	3 3/4	5 7/16	7/8	3	2	1 7/8	3 1/2	240,000
11-YAC-2-21	2 1/2	2-12	3 3/4	5 7/16	7/8	3	2	1 7/8	3 1/2	240,000
11-YAC-2-24	3	2 1/4-12	6 3/4	6 3/8	1	3 1/2	2 3/4	2 3/8	4 1/2	397,000
11-YAC-2-28	3 1/2	2 1/2-12	7	6 1/2	1	3 1/2	3 1/4	2 7/8	3 3/8	495,000
11-YAC-2-29	3 1/2	2 3/4-12	7	6 1/2	1	3 1/2	3 1/4	2 7/8	3 3/8	603,000
11-YAC-2-36	4 1/2	3 1/4-12	9 1/4	8 1/2	1	4 1/2	4	3 3/8	4 1/2	853,800
11-YAC-2-37	4 1/2	4 1/4-12	12 7/8	11 1/4	1	4 1/2	5 1/2	4 7/8	7	1,483,400

CLEVIS BRACKET

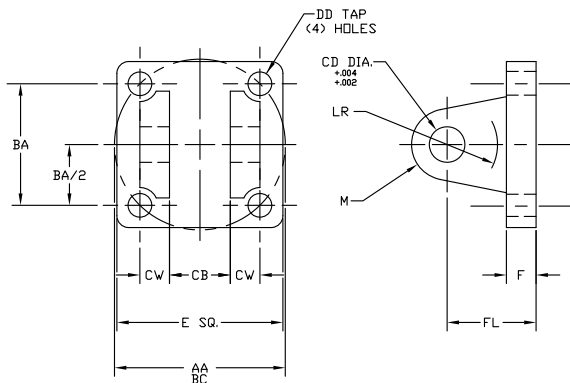

PART NUMBER	AA	BA	CB	CD	CW	DD	E	F	FL	LR	M
14-YCB-133-03	2.3	1 5/8	25/32	1/2	1/2	5/8-24	2 1/2	3/8	1 1/8	1/2	1/2
14-YCB-133-04	2.9	2 1/16	1 9/32	3/4	5/8	1/2-20	3	5/8	1 7/8	1	3/4
14-YCB-133-05	3.6	2 9/16	1 9/32	3/4	5/8	1/2-20	3 1/2	5/8	1 7/8	1 1/16	3/4
14-YCB-133-06	4.6	3 1/4	1 17/32	1	3/4	5/8-18	4 1/2	3/4	2 1/4	1 1/4	1
14-YCB-133-08	5.4	3 13/16	2 1/32	1 3/8	1	5/8-18	5	7/8	3	1 7/8	1 3/8
14-YCB-133-10	7.0	4 15/16	2 17/32	1 3/4	1 1/4	7/8-14	6 1/2	7/8	3 1/8	2	1 3/4
14-YCB-133-12	8.1	5 3/4	2 17/32	2	1 1/4	1-14	7 1/2	1	3 1/2	2 1/8	2
14-YCB-133-14	9.3	6 19/32	3 1/32	2 1/2	1 1/2	1 1/8-12	8 1/2	1	4	2 5/8	2 1/2
14-YCB-133-16	10.6	7 1/2	3 1/32	3	1 1/2	1 1/4-12	9 1/2	1	4 1/4	2 7/8	2 3/4
14-YCB-133-20	13.6	9 5/8	4 1/16	3 1/2	2	1 3/4-12	12 5/8	1 11/16	5 11/16	3 5/8	3 1/2
14-YCB-133-24	16.2	11 1/2	4 9/16	4	2 1/4	2-12	14 7/8	1 15/16	6 7/16	4	4

FEMALE EYE

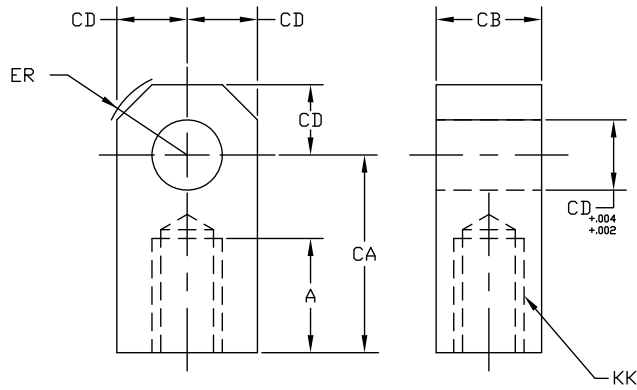

PART NUMBER	A	CA	CB	CD	ER	KK
13-YE-9303	3/4	1 1/2	3/4	1/2	5/8	7/16-20
13-YE-9304	1 1/8	2 1/16	1 1/4	3/4	7/8	3/4-16
13-YE-9306	1 5/8	2 13/16	1 1/2	1	1 3/16	1-14
13-YE-9306-M	1 1/8	2 3/8	1 1/2	1	1 7/16	7/8-14
13-YE-9308	2	3 7/16	2	1 3/8	1 9/16	1 1/4-12
13-YE-9310	2 1/4	4	2 1/2	1 3/4	2	1 1/2-12
13-YE-9312	3	5	2 1/2	2	2 1/2	1 7/8-12
13-YE-9312-M	2 1/4	4 3/8	2 1/2	2	2 7/8	1 3/4-12
13-YE-9314	3 1/2	5 13/16	3	2 1/2	2 13/16	2 1/4-12
13-YE-9316	3 1/2	6 1/8	3	3	3 1/4	2 1/2-12
13-YE9316-M	3 5/8	6 1/2	3 1/2	3	3 1/4	2 3/4-12
13-YE-9320	4 1/2	7 5/8	4	3 1/2	3 7/8	3 1/4-12
13-YE-9320-M	5	7 5/8	4	3 1/2	3 7/8	3 1/2-12
13-YE-9324	5 1/2	9 1/8	4 1/2	4	4 7/16	4-12
13-YE-9324-M	5 3/4	9 1/8	5	4	4 7/16	4 1/2-12

PIVOT PIN

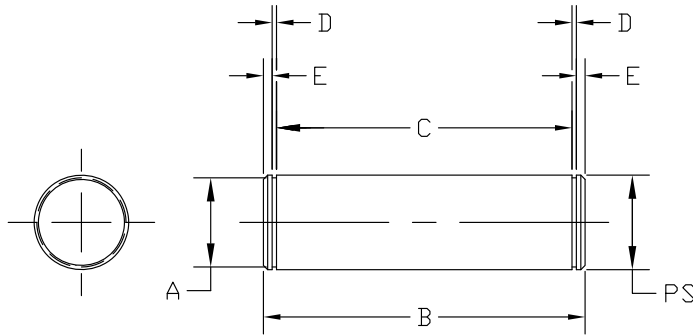

PART NUMBER	PIN SIZE	A	B	C	D	E
12-YP-9003-3-G-A	.500	.470	2.109	1.875	.039	.078
12-YP-9004-3-G-A	.750	.707	2.901	2.625	.046	.092
12-YP-9006-3-G-A	1.000	.943	3.401	3.125	.046	.092
12-YP-9008-3-G-A	1.375	1.295	4.461	4.125	.056	.122
12-YP-9010-3-G-A	1.750	1.655	5.545	5.125	.070	.140
12-YP-9012-3-G-A	2.000	1.891	5.545	5.125	.070	.140
12-YP-9014-3-G-A	2.500	2.366	6.625	6.190	.103	.172
12-YP-9016-3-G-A	3.000	2.844	6.780	6.250	.103	.206
12-YP-9020-3-G-A	3.500	3.322	8.845	8.250	.120	.240
12-YP-9024-3-G-A	4.000	3.782	9.845	9.125	.120	.240

EYE BRACKET

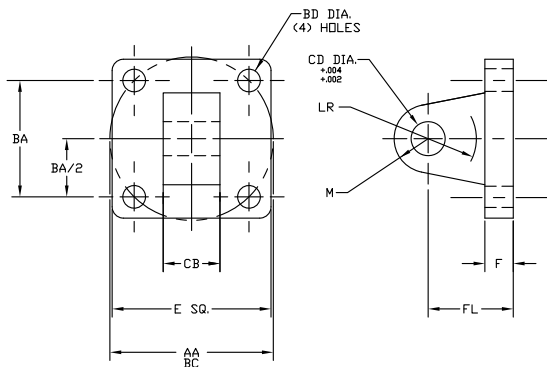

PART NUMBER	AA	BA	BD	CB	CD	E	F	FL	LR	M
15-YEB-8903	2.3	1 5/8	13/32	3/4	1/2	2 1/2	3/8	1 1/8	1/2	1/2
15-YEB-8904	3.6	2 9/16	17/32	1 1/4	3/4	3 1/2	5/8	1 7/8	1	3/4
15-YEB-8906	4.6	3 1/4	21/32	1 1/2	1	4 1/2	3/4	2 1/4	1	1
15-YEB-8908	5.4	3 13/16	21/32	2	1 3/8	5	7/8	3	1 1/8	1 3/8
15-YEB-8910	7.0	4 15/16	29/32	2 1/2	1 3/4	6 1/2	7/8	3 1/8	1 3/4	1 3/4
15-YEB-8910H	7.0	4 15/16	29/32	2 1/2	1 3/4	6 1/2	1 1/8	3 3/8	1 3/4	1 3/4
15-YEB-8912	8.1	5 3/4	1 1/32	2 1/2	2	7 1/2	1	3 1/2	2	2
15-YEB-8912H	8.1	5 3/4	1 1/32	2 1/2	2	7 1/2	1 1/2	4	2	2
15-YEB-8914	9.3	6 19/32	1 5/32	3	2 1/2	8 1/2	1	4	2 1/2	2 1/2
15-YEB-8914H	9.3	6 19/32	1 5/32	3	2 1/2	8 1/2	1 3/4	4 3/4	2 1/2	2 1/2
15-YEB-8916	10.6	7 1/2	1 9/32	3	3	9 1/2	1	4 1/4	2 3/4	2 3/4
15-YEB-8916H	10.6	7 1/2	1 9/32	3	3	9 1/2	2	5 1/4	2 3/4	2 3/4
15-YEB-8920	13.6	9 5/8	1 25/32	4	3 1/2	12 5/8	1 11/16	5 11/16	3 1/2	3 1/2
15-YEB-8924	16.2	11 1/2	2 1/32	4 1/2	4	14 7/8	1 15/16	6 7/16	3 7/8	4

SWIVEL EYE BRACKET

PART NUMBER	AA	BA	BD	CB	CD	E	F	FL	LR	M	DYNAMIC	STATIC
15-YSB-219-3-1	2.3	1 5/8	13/32	3/4	1/2	2 1/2	3/8	1 1/8	1/2	11/16	3,150	9,338
15-YSB-219-3-2	3.6	2 9/16	17/32	1 1/4	3/4	3 1/2	5/8	1 7/8	1	1 3/16	7,088	20,925
15-YSB-219-3-3	4.6	3 1/4	21/32	1 1/2	1	4 1/2	3/4	2 1/4	1	1 3/8	12,600	37,350
15-YSB-219-3-4	5.4	3 13/16	21/32	2	1 3/8	5	7/8	3	1 1/8	2	23,400	69,750
15-YSB-219-3-5	7.0	4 15/16	29/32	2 1/2	1 3/4	6 1/2	7/8	3 1/8	1 3/4	2 1/8	38,250	114,750
15-YSB-219-3-6	8.1	5 3/4	1 1/32	2 1/2	2	7 1/2	1	3 1/2	2	2 3/8	50,400	150,750

(Includes spacers to allow swivel action up to 7° and to make dimensions interchangeable with standard eye bracket.)
NOTE: To assure precision fit-up, pivot pins machined to special tolerances are furnished with all swivel eye brackets, unless otherwise specified.



ROD END COUPLER AND WELD PLATE

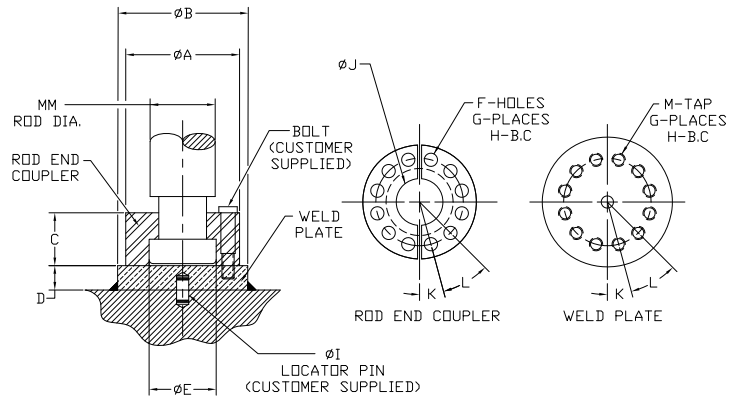

ROD END COUPLER PART#	WELD PLATE PART#	WELD PLATE MATERIAL	MM	A	B	C	D	E	F	G	H	I	J	K	L	M
18-FEC-062	18-FEC-062-WP	CD 1018	5/8	1.500	2.000	.562	.500	.656	.218	4	1.125	250	.406	45°	90°	10-24
18-FEC-100	18-FEC-100-WP	CD 1018	1	2.000	2.500	.875	.500	1.063	.281	6	1.500	250	.750	30°	60°	1/4-20
18-FEC-137	18-FEC-137-WP	CD 1018	1 3/8	2.500	3.000	1.000	.625	1.438	.343	6	2.000	250	.938	30°	60°	5/16-18
18-FEC-175	18-FEC-175-WP	CD 1018	1 3/4	3.000	4.000	1.250	.625	1.813	.343	8	2.375	250	1.187	22.5°	45°	5/16-18
18-FEC-200	18-FEC-200-WP	CD 1018	2	3.500	4.000	1.625	.750	2.063	.406	12	2.688	.375	1.438	15°	30°	3/8-16
18-FEC-250	18-FEC-250-WP	CD 1018	2 1/2	4.000	4.500	1.875	.750	2.625	.406	12	3.188	.375	1.875	15°	30°	3/8-16
18-FEC-300	18-FEC-300-WP	CD 1018	3	5.000	5.500	2.375	1.000	3.125	.531	12	4.000	.375	2.375	15°	30°	1/2-13
18-FEC-350	18-FEC-350-WP	A 36 HRS	3 1/2	5.875	7.000	2.625	1.000	3.625	.656	12	4.688	.375	2.625	15°	30°	5/8-11
18-FEC-400	18-FEC-400-WP	A 36 HRS	4	6.375	7.000	2.625	1.000	4.125	.656	12	5.188	.375	3.125	15°	30°	5/8-11
18-FEC-450	18-FEC-450-WP	A 36 HRS	4 1/2	6.875	8.000	3.125	1.000	4.625	.656	12	5.688	.375	4.625	15°	30°	5/8-11
18-FEC-500	18-FEC-500-WP	A 36 HRS	5	7.375	8.000	3.125	1.000	5.125	.656	12	6.188	.375	4.000	15°	30°	5/8-11
18-FEC-550	18-FEC-550-WP	A 36 HRS	5 1/2	8.250	9.000	3.875	1.250	5.625	.781	12	6.875	.375	4.500	15°	30°	3/4-10
18-FEC-700	18-FEC-700-WP	A 36 HRS	7	10.375	11.000	4.000	1.750	7.125	1.031	12	8.750	.375	5.938	15°	30°	1"-8

MALE SPHERICAL ROD EYE

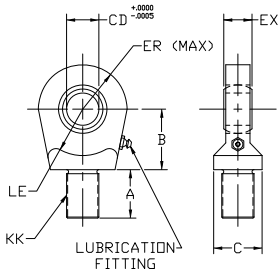

PART NUMBER	CD	KK	A	B	C	ER	EX	LE	MAX LOAD
13-MSRE-0500	.5000	7/16-20	11/16	7/8	7/8	7/8	7/16	3/4	2,600
13-MSRE-0750	.7500	3/4-16	1	1 1/4	1 5/16	1 1/4	21/32	1 1/16	7,080
13-MSRE-1000	1.000	1-14	1 1/2	1 7/8	1 1/2	1 3/8	7/8	1 7/16	12,590
13-MSRE-1375	1.3750	1 1/4-12	2	2 1/8	2	1 13/16	1 3/16	1 7/8	22,930
13-MSRE-1750	1.7500	1 1/2-12	2 1/8	2 1/2	2 1/4	2 3/16	1 17/32	2 1/8	38,220
13-MSRE-2000	2.000	1 7/8-12	2 7/8	2 3/4	2 5/8	2 5/8	1 3/4	2 1/2	50,360

SPHERICAL CLEVIS BRACKET

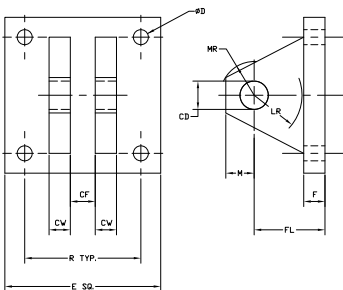

PART NUMBER	CD	CF	CW	D	E	F	FL	M	MR	LR	R
14-YCB-133-03-CBS	.500	.44	.50	.41	.300	.50	.50	.62	.94	2.05	
14-YCB-133-05-CBS	.750	.66	.62	.53	.375	.62	.200	.88	1.00	1.38	2.76
14-YCB-133-06-CBS	1.000	.88	.75	.53	.550	.75	.250	1.00	1.19	1.69	4.10
14-YCB-133-08-CBS	1.375	1.19	1.00	.66	.650	.88	.350	1.38	1.62	2.44	4.95
14-YCB-133-10-CBS	1.750	1.53	1.25	.91	.850	1.25	.450	1.75	2.06	2.88	6.58
14-YCB-133-12-CBS	2.000	1.75	1.50	.91	1.062	1.50	.500	2.00	2.38	3.31	7.92

SPHERICAL PINS

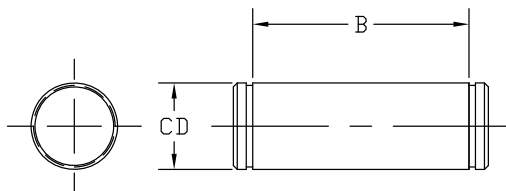

PART NUMBER	CD	B	
12-YP-9003-3-G-CBS	.4997	+0.000 -0.004	1 9/16
12-YP-9004-3-G-CBS	.7497	+0.000 -0.005	2 1/32
12-YP-9006-3-G-CBS	.9997	+0.000 -0.005	2 1/2
12-YP-9008-3-G-CBS	1.3746	+0.000 -0.006	3 5/16
12-YP-9010-3-G-CBS	1.7496	+0.000 -0.006	4 7/32
12-YP-9012-3-G-CBS	1.9996	+0.000 -0.007	4 15/16

STANDARD ROD END STYLES

ROD END STYLE #	DIMENSIONS	ROD END STYLE #	DIMENSIONS																																																																																								
#2** STANDARD MALE (NFPA-SM)		#4 STANDARD FEMALE (NFPA-SF)																																																																																									
#1 STANDARD MALE (NFPA-IM)		<table border="1"> <thead> <tr> <th rowspan="2">ROD</th> <th colspan="4">ADDITIONAL DIMENSIONS</th> <th rowspan="2">STYLE 8</th> </tr> <tr> <th colspan="4">STYLE 9</th> </tr> <tr> <th>MM</th> <th>AC +/- .030</th> <th>AD +/- .010</th> <th>AE +/- .000/- .010</th> <th>AF +/- .010</th> <th>FT</th> </tr> </thead> <tbody> <tr> <td>5/8</td> <td>1 1/8</td> <td>5/8</td> <td>1/4</td> <td>3/8</td> <td>5/8-18</td> </tr> <tr> <td>1</td> <td>1 1/2</td> <td>15/16</td> <td>3/8</td> <td>11/16</td> <td>1-14</td> </tr> <tr> <td>1 3/8</td> <td>1 3/4</td> <td>1 1/16</td> <td>3/8</td> <td>7/8</td> <td>1 3/8-12</td> </tr> <tr> <td>1 3/4</td> <td>2</td> <td>1 5/16</td> <td>1/2</td> <td>1 1/8</td> <td>1 3/4-12</td> </tr> <tr> <td>2</td> <td>2 5/8</td> <td>1 11/16</td> <td>5/8</td> <td>1 3/8</td> <td>2-12</td> </tr> <tr> <td>2 1/2</td> <td>3 1/4</td> <td>1 15/16</td> <td>3/4</td> <td>1 3/4</td> <td>2 1/2-12</td> </tr> <tr> <td>3</td> <td>3 5/8</td> <td>2 7/16</td> <td>7/8</td> <td>2 1/4</td> <td>3-12</td> </tr> <tr> <td>3 1/2</td> <td>4 3/8</td> <td>2 11/16</td> <td>1</td> <td>2 1/2</td> <td>3 1/2-12</td> </tr> <tr> <td>4</td> <td>4 1/2</td> <td>2 11/16</td> <td>1</td> <td>3</td> <td>4-12</td> </tr> <tr> <td>4 1/2</td> <td>5 1/4</td> <td>3 3/16</td> <td>1 1/2</td> <td>3 1/2</td> <td>4 1/2-12</td> </tr> <tr> <td>5</td> <td>5 3/8</td> <td>3 3/16</td> <td>1 1/2</td> <td>3 7/8</td> <td>5-12</td> </tr> <tr> <td>5 1/2</td> <td>6 1/4</td> <td>3 15/16</td> <td>1 7/8</td> <td>4 3/8</td> <td>5 1/2-12</td> </tr> </tbody> </table>		ROD	ADDITIONAL DIMENSIONS				STYLE 8	STYLE 9				MM	AC +/- .030	AD +/- .010	AE +/- .000/- .010	AF +/- .010	FT	5/8	1 1/8	5/8	1/4	3/8	5/8-18	1	1 1/2	15/16	3/8	11/16	1-14	1 3/8	1 3/4	1 1/16	3/8	7/8	1 3/8-12	1 3/4	2	1 5/16	1/2	1 1/8	1 3/4-12	2	2 5/8	1 11/16	5/8	1 3/8	2-12	2 1/2	3 1/4	1 15/16	3/4	1 3/4	2 1/2-12	3	3 5/8	2 7/16	7/8	2 1/4	3-12	3 1/2	4 3/8	2 11/16	1	2 1/2	3 1/2-12	4	4 1/2	2 11/16	1	3	4-12	4 1/2	5 1/4	3 3/16	1 1/2	3 1/2	4 1/2-12	5	5 3/8	3 3/16	1 1/2	3 7/8	5-12	5 1/2	6 1/4	3 15/16	1 7/8	4 3/8	5 1/2-12
ROD	ADDITIONAL DIMENSIONS				STYLE 8																																																																																						
	STYLE 9																																																																																										
MM	AC +/- .030	AD +/- .010	AE +/- .000/- .010	AF +/- .010	FT																																																																																						
5/8	1 1/8	5/8	1/4	3/8	5/8-18																																																																																						
1	1 1/2	15/16	3/8	11/16	1-14																																																																																						
1 3/8	1 3/4	1 1/16	3/8	7/8	1 3/8-12																																																																																						
1 3/4	2	1 5/16	1/2	1 1/8	1 3/4-12																																																																																						
2	2 5/8	1 11/16	5/8	1 3/8	2-12																																																																																						
2 1/2	3 1/4	1 15/16	3/4	1 3/4	2 1/2-12																																																																																						
3	3 5/8	2 7/16	7/8	2 1/4	3-12																																																																																						
3 1/2	4 3/8	2 11/16	1	2 1/2	3 1/2-12																																																																																						
4	4 1/2	2 11/16	1	3	4-12																																																																																						
4 1/2	5 1/4	3 3/16	1 1/2	3 1/2	4 1/2-12																																																																																						
5	5 3/8	3 3/16	1 1/2	3 7/8	5-12																																																																																						
5 1/2	6 1/4	3 15/16	1 7/8	4 3/8	5 1/2-12																																																																																						

OPTIONAL ROD END STYLES

ROD END STYLE #	DIMENSIONS	ROD END STYLE #	DIMENSIONS
#5		#3 (NFPA-LF)	
#6		#7 (NFPA-PL)	
#9		#8 (NFPA-FM)	

**** MALE ROD END STYLE #2 WILL BE FURNISHED UNLESS OTHERWISE SPECIFIED**

(4) SPANNER HOLES USED INSTEAD OF FLATS ON 4" DIA. AND LARGER.

NOTE: CONSULT FACTORY FOR ROD END CONFIGURATIONS OTHER THAN THOSE SHOWN.

NOTE: ALL YATES MOUNTING ACCESSORIES ARE DESIGNED TO FIT #2 ROD END STYLES



