



YOUR CYLINDER SOURCE[®]

TIE ROD | WELDED | MILL DUTY | REPAIR

SCHEDULE A CONSULTATION

With over 50 years of experience in hydraulic and pneumatic cylinders, our team can provide industry leading solutions for your cylinder needs.



TIE ROD CYLINDERS

THE ULTIMATE IN VERSATILITY

INTERCHANGEABILITY

When you're looking for a reliable tie rod cylinder from heavy-duty to light-duty hydraulics and pneumatics versatility, Yates has one that's sure to fit your needs.

- Bore Sizes From 1.5" – 24"
- 23 Different Mount Types
- NFPA, JIC Interchangeability
- 3 Year Limited Warranty

Heavy Duty Hydraulic (H6)

- Bore sizes from 1.5" - 24", 20 mounting styles
- JIC-NFPA Interchangeability
- 3,000 PSI

Pneumatic Heavy Duty (A4) Hydraulic Medium Duty (H4) Pneumatic Permanently Lubricated (L4)

- Bore sizes from 1.5" - 20", 23 mounting styles
- JIC-NFPA Interchangeability
- Pressures up to 250 PSI pneumatic of 400 to 1,500 PSI hydraulic

Pneumatic (A2) Hydraulic Light Duty (H2)

- Bore sizes from 1.5" - 8", 20 mounting styles
- JIC-NFPA Interchangeability
- Pressure up to 250 PSI pneumatic or 400 PSI hydraulic

Special Cylinders available per customer requirements.

FLEXIBILITY

Ideal for demanding foundry, steel mill, plastics, and stamping industries. Tie rod cylinder applications range from clamping, shearing and forging, to bending, press, and counterbalance. All our tie rod cylinders are manufactured at our St. Clair Shores, Michigan facility.



WELDED BODY CYLINDERS

PERFORMANCE & RELIABILITY – THE WHOLE PACKAGE

DEPENDABILITY

Yates has a wide range of rugged, sturdy, and dependable welded-body cylinders designed to meet industry equipment demands.

Hydraulic Heavy Duty (WH)

- Bore Sizes From 1.5" – 12" with Screw in gland
- CPO Rod
- 3,000 PSI

Hydraulic Medium Duty (WM)

- Bore Sizes From 1.5" – 6" with Snap Ring Gland
- CPO Rod
- 1,800 – 2,500 PSI

Hydraulic Severe Duty (WS)

- Bore Sizes From 4" – 12"
- Increased wall tubing
- IHCP Rod
- 3,000 PSI
- Built for extreme applications

Pneumatic (WP)

- Bore Sizes From 1.5" – 6" with Snap Ring Gland
- CPO Rod
- 250 PSI

Special Cylinders available per customer requirements.



SUITABILITY

Yates welded hydraulic cylinders perform in a vast range of manufacturing applications. Manufactured exclusively at our Austell, Georgia facility, our welded cylinders are ideal for your medium and heavy duty applications, including packaging and extreme milling.

MILL DUTY CYLINDERS

YOUR FACTORY FLOOR HAS MET ITS MATCH

DURABILITY

Yates manufactures a workhorse of a mill duty cylinder—designed to work under extreme pressure and physical wear while meeting all of your production needs.

Heavy Duty Hydraulic Mill (MH)

- 6 Mounting Styles
- Bore Sizes From 2" – 24" with IHCP Rod
- 3,000 PSI
- Built for extreme mill applications

Pneumatic Mill Duty (MP)

- 6 mounting styles
- Bore Sizes From 2" – 24" with CPO Rod
- 250 PSI

Special Cylinders available per customer requirements.



ACCESSIBILITY

Manufactured at our Decatur, Alabama facility, Yates mill duty cylinders feature high load piston design, heavy wall tubing, and induction hardened, chrome plated rods. Yates solid mill duty cylinders are built tough to keep on performing.

24/7

CYLINDER REPAIR

THE LARGEST & MOST COMPLETE FACILITIES IN THE MIDWEST

TIMELESS

Profit-robbing breakdowns don't always happen during business hours. That's why we're available 24 hours per day, 365 days per year to handle your repair. Yates provides:

- Four locations / six plants = 365,000 sq ft
- Best equipped repair facilities east of the Mississippi
- Outstanding customer service
- Constant dialogue with plant personnel to reduce cylinder failure
- 50+ years in the business
- **Repairs on ALL makes and models**
- 24/7 Emergency service at all locations
- Rapid response times
- Quick delivery and expediting
- ISO 9001:2015 certified
- Warranty on all cylinder repairs
- In-house design team
- Detailed failure reports
- Increased cylinder life
- Fewer cylinder changes per month/year
- Less overall cylinder spending
- Upgrades on cylinders to help reduce repair costs

TRUSTED

As an integral part of our quality process, all hydraulic cylinder repairs are tested to their rated pressures before leaving our facility. With test stands rated for 10,000 PSI and fixtures for special applications like water service, steel mills and marine, you can be assured your component is ready for use when you receive it.

PRICELESS

With over 80 state of the art CNC machines, grinders, honing machines, and lathes that can machine up to 500+ inches center to center, we deliver faster turnaround and superior quality compared to the competition. At Yates, we take pride in restoring every cylinder to original specifications or better, ensuring precision and reliability the first time, every time.

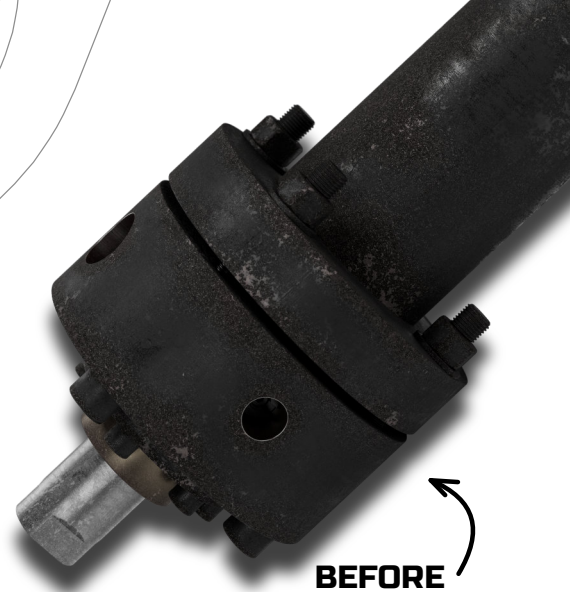

BEFORE

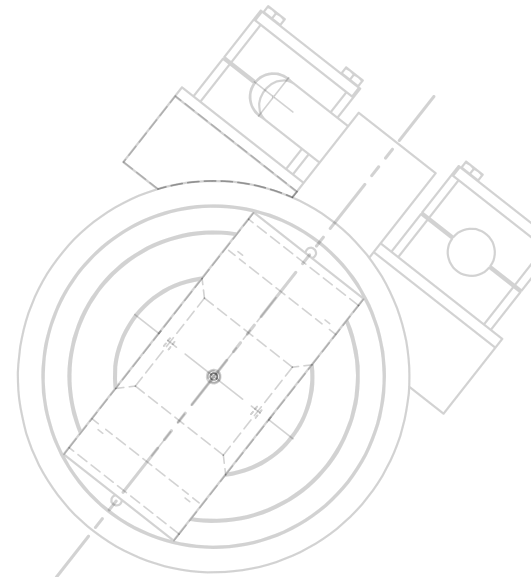

AFTER



GOING STRONG SINCE

1972

Yates Cylinders Michigan (HQ)

23050 Industrial Dr. E.
St. Clair Shores, MI 48080

Phone: 586.778.7680

Email: sales@yatesind.com

Yates Cylinders Ohio

550 Bellbrook Ave.
Xenia, OH 45385

Phone: 513.217.6777

Email: ohsales@yatesind.com

Yates Cylinders Alabama

55 Refreshment Place
Decatur, AL 35601

Phone: 256.351.8081

Email: alsales@yatesind.com

Yates Cylinders Georgia

7750 The Bluffs
Austell, GA 30168

Phone: 678.355.2240

Email: gasales@yatesind.com

GROWTH

Yates Industries has grown from a small fluid power distributor in 1972 into one of the nation's leading manufacturers and re-builders of hydraulic and pneumatic cylinders. With over 365,000 sq. ft. of state-of-the-art manufacturing and repair space and multiple facilities across Michigan, Georgia, Alabama, and Ohio, we deliver industry-leading quality, capacity, and turnaround times.

Guided by the forward-thinking leadership of William H. Yates III, the demand for Yates products and services continues to expand nationwide. Our strategically positioned outside sales team provides on-site support and hands-on expertise, ensuring customers receive fast, personalized service wherever they operate.

Today, Yates remains committed to continuous growth and innovation, earning our reputation as one of the largest and most complete cylinder manufacturers in the United States.

EXPANSION

For more than 50 years, we proudly serve a broad range of industries, including Defense, Material Handling, Agriculture, Oil & Gas, Marine, Metal Forming, Plastics, Steel, Food, and OEMs. Our mission is to deliver exceptional quality, service, and reliability. We achieve this through our most valuable asset—our people. With an unwavering commitment to excellence and pride in our work, we strive to set the standard by which our competitors are measured.



MADE IN THE USA

WWW.YATESIND.COM